

# Grid synchronization and symmetrical components extraction with PLL algorithm for grid connected power electronic converters – a review

M. BOBROWSKA-RAFAL\*, K. RAFAL, M. JASINSKI, and M.P. KAZMIERKOWSKI

Institute of Control and Industrial Electronics, Warsaw University of Technology, 75 Koszykowa St., 00-662 Warsaw, Poland

**Abstract.** In this paper, a review of Phase Locked Loop (PLL) algorithms and symmetrical component extraction methods intended for grid-connected power electronic converters are presented. Proposed classification is based on voltage representation in three coordinates: natural (abc), stationary ( $\alpha/\beta$ ) and rotating coordinates (dq). The three selected algorithms are described in details: Dual Second Order Generalized Integrator (DSOGI-PLL), Dual Virtual Flux – both in stationary coordinates. The third one, in rotating dq coordinates, is Dual Synchronous Reference Frame PLL (DSRF-PLL). A comparison of PLL algorithms is presented. Also, selected experimental results are given to verify practical application of discussed algorithms.

**Key words:** Phase Locked Loop (PLL), symmetrical component extraction, grid synchronization, grid-connected converter, smart grid, Renewable Energy Sources (RES), voltage dip, higher harmonics, power quality.

## 1. Introduction

Electrical grid is always struggling with problem of voltage disturbances. Recently, this issue has become substantially severe, as the conventional electrical infrastructure is extending. Revolution of electrical system has been proceeding since introduction of Distributed Generation (DG) [1] and Renewable Energy Sources (RES) to the electrical grid. Integration of different technologies leads to increasing diversity of grid, including smart grids, and forces more restrictive standards. Restrictions for RES and DG power quality are given in each country in so called “grid codes”. Among grid requirements for RES there are: operation with certain power factor (close to unity), limited harmonic content of injected current, continuous operation under voltage distortions, etc. Most of these requirements can be satisfied with proper control of grid connected converter [2–4]. Therefore, RES use power electronic converters to adapt generated power parameters to those required by electrical grid.

On the other hand, many of power electronic devices are introduced to the grid specially to compensate for decreasing power quality. Most of installations are ordered by industrial customers to protect against voltage dips, higher harmonics or flicker and constitute group called CUPS (Custom Power Systems). The CUPS includes devices like: DVR, D-STATCOM, UPS and others. There are also devices installed for transmission system support, called FACTS (Flexible AC Transmission Systems), like: STATCOM, SVC, SSSC, UPFC and others [5, 6].

Every of above mentioned grid-connected device has to be precisely synchronized with grid voltage. It is significant due to generating high quality energy by RES as well as com-

pensating energy by CUPS or FACTS [7]. It is essential also for different kinds of load, which without synchronization, introduce distortions to grid voltage. Therefore, accurate phase angle information of grid voltage is indispensable for proper operation of every grid-connected power converter. Table 1 contains different grid-connected devices with necessary grid synchronization, cooperating with power converters.

Table 1  
Grid-connected devices, employing power converters with grid synchronization

Group of devices	Applications
Renewable Energy Sources (RES)	wind power plants, photovoltaic plants, wave energy plants, etc.
Custom Power Systems (CUPS)	Uninterruptible Power Supply (UPS), Active Power Filter (APF), Dynamic Voltage Restorer (DVR), D-STATCOM, etc.
Flexible AC Transmission Systems (FACTS)	Static Compensator (STATCOM), Static Var Compensator (SVC), Static Series Synchronous Compensator (SSSC), etc.
Loads	DC loads cooperating with grid-connected converters (AC/DC), AC loads with AC/DC/AC converters, for ex. active front end (AFE) in adjustable speed drives (ASD).

In order to obtain synchronization Phase Locked Loop (PLL) is implemented to control algorithm of grid-connected converter. The objective of PLL's is calculation of stable and undisturbed phase angle of grid during any voltage conditions, especially including distorted voltage.

A variety of PLL structures are described in literature but there is no clear classification. This paper presents plain division based on coordinates in which PLL operates. The

\*e-mail: bobrowskam@gmail.com

classification focuses only on three-phase applications aimed for digital implementation on DSP platform.

In this article three best promising PLL algorithms are described. The selection is based on previous reviews [8–12] and authors’ deep research. Moreover, in this paper evaluation criterions are proposed to verify the best operating algorithm. In simulation process three chosen algorithms were verified due to selected criterions. The results of analysis are summarized in conclusions.

## 2. Application and structure

The PLL structure is a feedback algorithm, which automatically adjusts the phase of locally generated signal to match the phase of an input signal. Basic concept was presented by Bellescise in 1932 [13] and it was widely used in radio communication. In grid-connected converter applications, PLL is crucial for control algorithm performance. Among common tasks, where PLL is used are:

- Active and reactive power control;
- Voltage regulation, dips and flicker compensation;
- Grid monitoring: fault detection by angle/frequency detection, power factor calculation;
- Smart grid control: islanding detection, connecting/disconnecting process control, fault ride through;
- Current control: higher harmonics and reactive power compensation;
- others.

The basic scheme of PLL consists of three block units as shown in Fig. 1a. The first one is Phase Detector (PD), which is responsible for generation signal proportional to the phase difference between input signal and the signal generated by internal oscillator called VCO. The task of Loop Filter (LF) is to attenuate the high-frequency components from PD output. The Voltage Controlled Oscillator (VCO) generates at its out-

put a periodic signal, which frequency is shifted with respect to a given basic frequency.

This concept suits to basic PLL algorithms operating in *abc* natural coordinates, when grid voltage is not polluted. In a distorted voltage conditions, the synchronization with electrical grid becomes a challenge. The phase detection by direct methods can lead to significant errors due to voltage variations like dips, change of phase and frequency, higher harmonics or low harmonic distortions, like flicker. Distorted phase angle information affects control algorithm. Under distorted grid voltage, converter no longer produces or consumes energy fulfilling quality requirements. It can lead to “domino effect”, where one distortion causes another, and leads to serious power deterioration. Hence, PLL should be immune to any variation in electrical system.

After deep analysis and research, authors claim that PLL in natural coordinates are not sufficiently immune to grid voltage variations and only transformation to  $\alpha\beta$  or *dq* coordinates assures proper filtration of above mentioned distortions.

Advanced PLLs, operating in  $\alpha\beta$  and *dq* coordinates, have different, than the classic algorithms, structure presented in Fig. 1b. It consists of:

- Coordinates transformation block (from *abc* to *dq* or  $\alpha\beta$ );
- Component Extractor (CE) calculates and filtrates positive and negative voltage components. For further calculations only positive voltage component is considered. The negative component can optionally be employed in independent control of positive and negative current components;
- Phase Detector (PD) has same functionality as in basic scheme of Fig. 1a;
- Voltage Controlled Oscillator (VCO) calculates correct phase angle  $\varphi$ .

As VCO Synchronous Reference Frame–PLL (SRF-PLL) is employed. When  $\alpha\beta$  transformation is used, less immune *arcus tangens* function is applied for phase angle calculations.

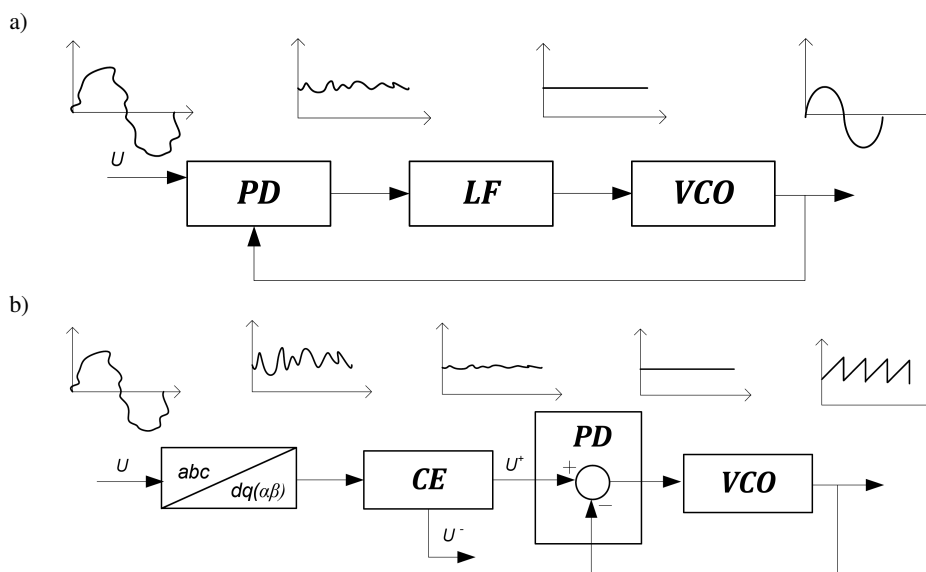

Fig. 1. Basic Concepts of PLL algorithm: a) classical structure, b) advanced structure PD – Phase Detector, SE – Sequence Estimator, LF – Loop Filter, VCO – Voltage Controlled Oscillator

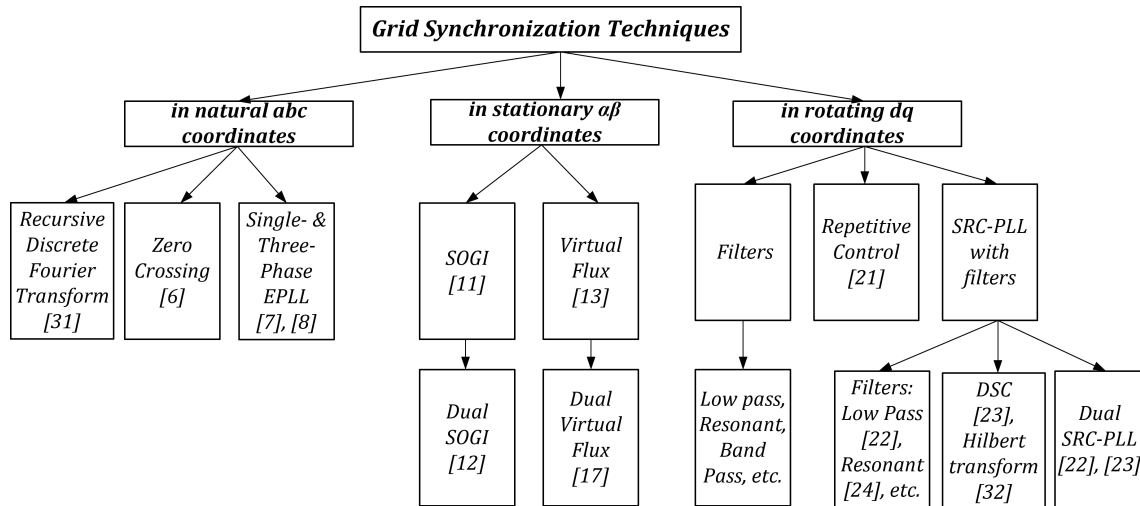

Fig. 2. Classification of synchronization techniques for three-phase grid-connected converter: SRF – Synchronous Reference Frame, EPLL – Enhanced PLL, SOGI – Second Order Generalized Integrator, DSC – Delayed Signal Cancellation

The Component Extractor CE can operate in three types of reference coordinates: natural ( $abc$ ), stationary ( $\alpha\beta$ ) and rotating coordinates ( $dq$ ). In the literature variety of different PLL algorithms exists, but each of them can be assigned to one of these three groups, depending on the reference coordinates. Basing on this criterion, classification of PLL algorithms is shown in Fig. 2. To each coordinate used, a few examples of common used PLL are given.

### 3. Requirements

According to latest trends in converters' control, any PLL algorithm should execute fast and precise detection of the amplitude and phase of the positive and negative voltage components [9]. It is possible with mathematical transformations based on instantaneous symmetrical components theory [14]. Separate voltage components are calculated using decoupling networks in respective reference coordinates. In this paper three PLL structures including sequence estimation were chosen for studies. Yet, none criterion, giving simple method of comparison, has not been set. One method [15] is based on parameters comparison of second order transfer function of PLL algorithms. It is complicated and does not give any clear results and conclusions. Other methods also do not give obvious classification.

The grid voltage distortions cause variations of positive and negative voltage component in all coordinates. The best visibility of distortions can be achieved in  $dq$  coordinates due to transforming sinusoidal signals (from  $abc$  and  $\alpha\beta$ ) into DC quantities. In  $dq$  coordinates, ideal voltages are uninterrupted DC signals. When a distortion in grid voltage occurs, the variations of DC signal is much better noticeable and filtered than in sinusoidal system (like  $abc$  or  $\alpha\beta$ ). The second advantage of transforming voltages (even in  $\alpha\beta$ ) to  $dq$  is using SRF-PLL, which gives the best operating performance as VCO.

Therefore, the criterions for measuring PLL operation are:

- Overshoot of estimated positive voltage component in  $q$  axis  $U_q^+$ ;

- Settling time of  $U_q$ ;
- Overshoot of angular speed error  $\Delta\omega$ ;
- Settling time of  $\Delta\omega$ ;
- THD of sinus function of estimated phase angle;

The settling time  $t_s$  and overshoot are measured from the start of transient to the time in which the system stays within 2% of the steady-state response. The comparison of three PLL algorithms were carried out, according to these criterions.

### 4. PLL in $abc$ natural coordinates

Filtering method in natural reference coordinates does not require any coordinate transformation – only grid voltage measurement signals are used. Most of the PLL in  $abc$  axes operates as single-phase. There are solutions using three independent PLLs for every phase or only one algorithm for e.g. in  $a$  phase. This concept is not reliable due to unsymmetrical distortion in grid voltage. Three different PLLs significantly increase computational effort.

The most popular phase detection algorithm is zero crossing method [10, 16]. The significant disadvantage of the method is sensitivity for any voltage distortions. Therefore, it is not used in power applications. Some applications of single-phase PLL employ Fourier analysis – mathematical tool transforming given function to frequency domain and vice versa. As a PLL the Recursive Discrete Fourier Transform (RDFT) is used instead of Discrete Fourier Transform to reduce computational effort. The RDFT is used to implement a discrete adaptive band-pass filter. The serious disadvantage of methods, based on Fourier analysis, is exact dependence on fundamental frequency, especially under frequency variations.

Among PD methods in  $abc$  coordinates, the phase adaptive PLL, using a single-phase enhanced phase-locked loop (EPLL), deserves mentioning. It bases on idea of an adaptive band pass filter [12, 17, 18]. In this method, a set of two orthogonal signals, synchronized with the phase voltage, are outputs of the EPLL. These signals are processed using the instantaneous symmetrical components method to calculate

the positive sequence component of the grid voltage. Among disadvantages of the EPLL there are high complexity and low dynamics.

Other concept bases on representation of single phase signal as an virtual vector and use of PLL operating in stationary coordinates. However, it requires generation of orthogonal component – so called quadrature signal generation, therefore is characterized by delay. Among them are Delay Signal Cancellation (DSC) [19], described below or Hilbert Transform [20].

**5. PLL in dq synchronous rotating coordinates**

In the PLL algorithm operating in dq rotating coordinates, voltage signals are transformed to Synchronous Rotation Frame (SRF), where in ideal conditions three-phase sinusoidal voltages become two DC signals. The basic solution of PLL in SRF, called SRF-PLL, is presented in Fig. 3 [21]. It is based on PI controller, widely used in almost all control algorithms for converters, for example in Voltage Oriented Control (VOC) [2, 3]. The PI controller adjusts estimated frequency, by controlling  $U_q$  to be zero, so that *d*-axis follows grid voltage vector. Signal of integrated frequency represents phase angle  $\varphi^*$  and is used for coordinates transformation.

Any distortion of grid voltage is seen as a disturbance in SRF, particularly negative voltage sequence becomes  $2^{nd}$  harmonic component. It causes variation of estimated phase angle resulting in improper coordinates transformation.

One of basic solution for this problem is SRF-PLL with LPF. However, the dynamic is slow and phase shift is introduced to signal. The second is resonant filters [22], which is also slow but is immune to higher harmonics and does not lead in phase shift. Less common technique for PLL is Moving Average Filter, which performance is similar to LPF [23]. Repetitive controller operates like band-pass filter and improves elimination of higher harmonics. It filters out odd harmonics and even are left. Repetitive controller presented in [24] is immune to  $2^{nd}$  harmonic as well. Delayed Signal Cancellation (DSC) is a filtering method, based on combination of time delayed synchronous coordinates magnitudes [19, 25]. To eliminate negative sequence, which appears as  $2^{nd}$  harmonic oscillation, the output of DSC filter is a sum of voltage in *d* or *q* axis and the same voltage delayed by quarter of period. There are also PLLs' method based on predictive filters and moving average filters [26], phasors estimation [27] or lead filter (lead SRF-PLL) [28].

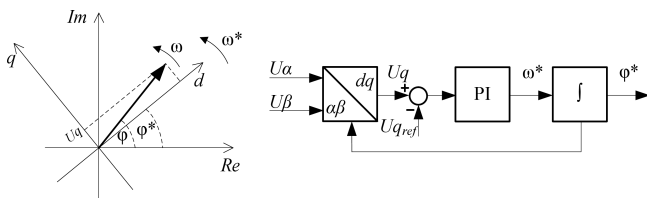

Fig. 3. Concept of Synchronous Reference Frame PLL (SRF-PLL)

**5.1. Dual Synchronous Reference Frame PLL (DSRF-PLL).** The most promising PLL in *dq* axes is Dual Syn-

chronous Reference Frame PLL (DSRF-PLL). In this method the voltage vector is divided into two components: positive (+) and negative (-), rotating in opposite directions. Positive and negative SRF are simultaneously filtering out voltages ( $U_d^+, U_q^+, U_d^-, U_q^-$ ) by means of decoupling cell presented in Fig. 4a. Application of cross-feedback decoupling network gives a fast and precise estimation [29, 30].

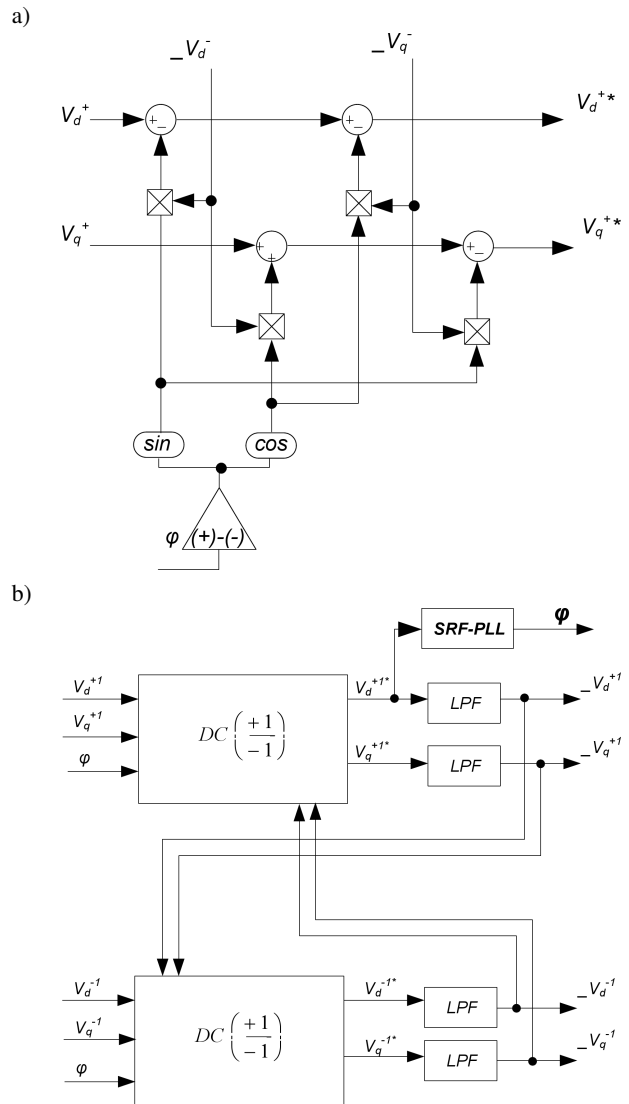

Fig. 4. a) decoupling cell dismantling positive and negative voltage components; b) block scheme of Dual Synchronous Reference Frame (DSRF)

In decoupling network, after a stabilization period, the signal on the axes DSRF are free of variations and the amplitude of the *m* and *n* components are precisely calculated [31], what is presented in Fig. 4b. The cut-off frequency sets around  $\omega/\sqrt{2}$ , gives the best results ( $\omega$  is estimated fundamental grid frequency).

For calculating phase angle from positive voltage component  $U_d^+$ , standard SRF-PLL is employed. The concept is presented in [19, 32] and evaluation is given in [33, 34].

### 6. PLL in $\alpha\beta$ stationary reference coordinates

Representation of three-phase voltage as a complex vector in  $\alpha\beta$  plane allows to use simple *arcus tangens* function for phase extraction. As this methods operates without any filters, it instantaneously responds to any kind of distortion in grid voltage. Hence, the angle calculated by *arcus tangens* is often a reference for content of distortions. Many solutions for distortion rejection in  $\alpha\beta$  were proposed: filters basing on notch, vector or low pass filters, which effectiveness is not satisfactory [35, 36], as well as band-pass or delay filters [37].

**6.1. Dual Second Order Generalized Integrator DSOGI-PLL.** Among many approaches of filtering in  $\alpha\beta$  coordinates, the frequency-adaptive positive-sequence detection, called Dual Second Order Generalized Integrator DSOGI can be distinguished. It utilizes Second Order Generalized Integrator (SOGI) based filters [37], shown in Fig. 5. They are characterized by second order transfer functions:

$$G_1(s) = \frac{U'}{U} = \frac{k\omega s}{s^2 + k\omega s + \omega^2}, \quad (1)$$

$$G_2(s) = \frac{U''}{U} = \frac{k\omega^2}{s^2 + k\omega s + \omega^2}, \quad (2)$$

where  $\omega$  – grid voltage angular frequency;  $k$  – damping factor. The lower  $k$  is, the better higher harmonics are damped, but dynamics is reduced. In literature [5, 37]  $k$  factor was selected experimentally and is equal to  $1/\sqrt{2}$ .

Characteristic features that enable their use for filtering is unity gain and certain phase shifts for nominal frequency: first transfer function (1) does not introduce phase delay,

while second (2) shifts signal by  $-90^\circ$ , generating orthogonal component. This feature allows to introduce coupling network to estimate positive sequence of grid voltage. The phase of filtered signal can be calculated either by *arcus tangens* function or by SRF-PLL. Using of SRF-PLL is described below. The DSOGI is characterized by good filtering of most distortions. What is significant, also higher frequencies are effectively damped.

**6.2. Virtual Flux.** The idea of Virtual Flux (VF) in application for power converters control was presented by Bhattacharaya in 1996 [38] and was consequently developed and improved [39, 40]. The flux components  $\psi_\alpha$  and  $\psi_\beta$  are calculated as:

$$\begin{bmatrix} \psi_\alpha \\ \psi_\beta \end{bmatrix} = \begin{bmatrix} \int U_\alpha dt \\ \int U_\beta dt \end{bmatrix}. \quad (3)$$

To eliminate grid voltage sensors, virtual flux can be estimated as:

$$\begin{bmatrix} \psi_{g,\alpha} \\ \psi_{g,\beta} \end{bmatrix} = \begin{bmatrix} \int U_{conv,\alpha} dt \\ \int U_{conv,\beta} dt \end{bmatrix} - \begin{bmatrix} Li_\alpha \\ Li_\beta \end{bmatrix}. \quad (4)$$

Because of integral relationship, the virtual flux converter vector is  $90^\circ$  lagging from the inverter voltage vector. Finally, grid voltage vector position is expressed as:

$$\rho = \arctan \left( \frac{\psi_{g,\alpha}}{\psi_{g,\beta}} \right) + \frac{\Pi}{2}. \quad (5)$$

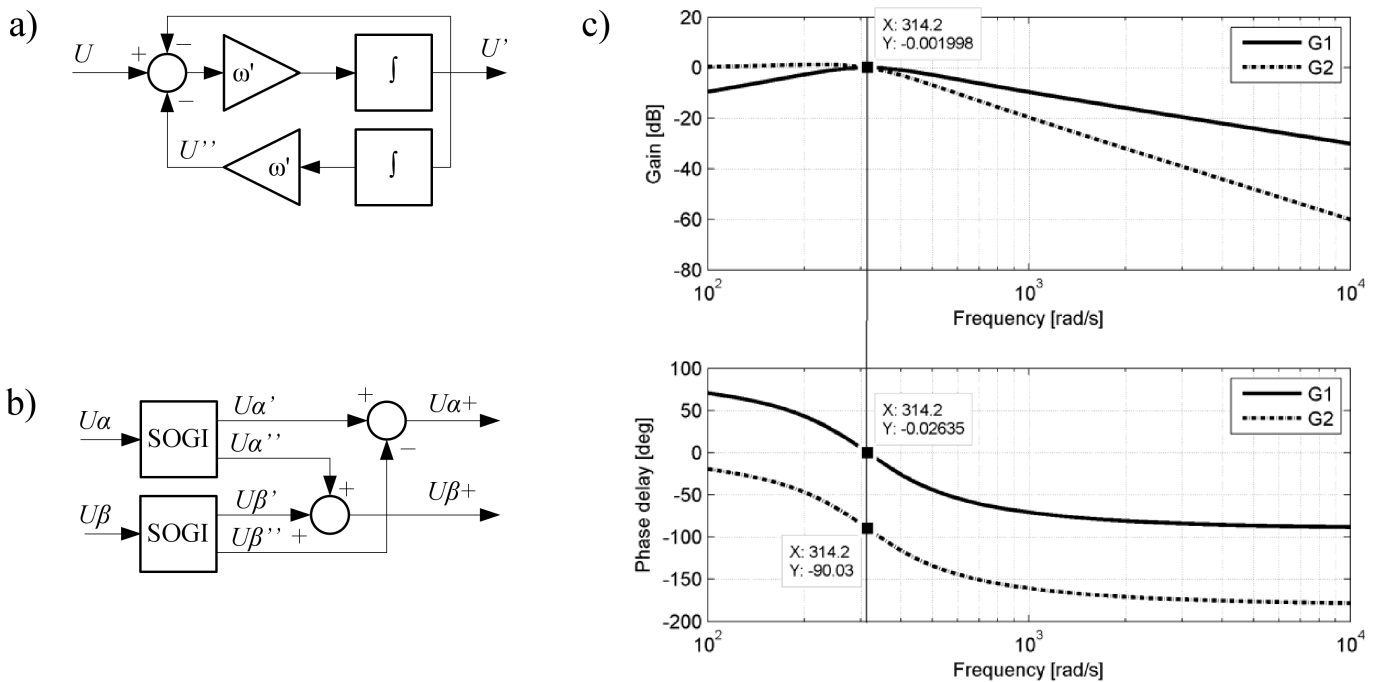

Fig. 5. Second Order Generalized Integrator (SOGI): a) basic scheme; b) dual SOGI; c) Bode diagram

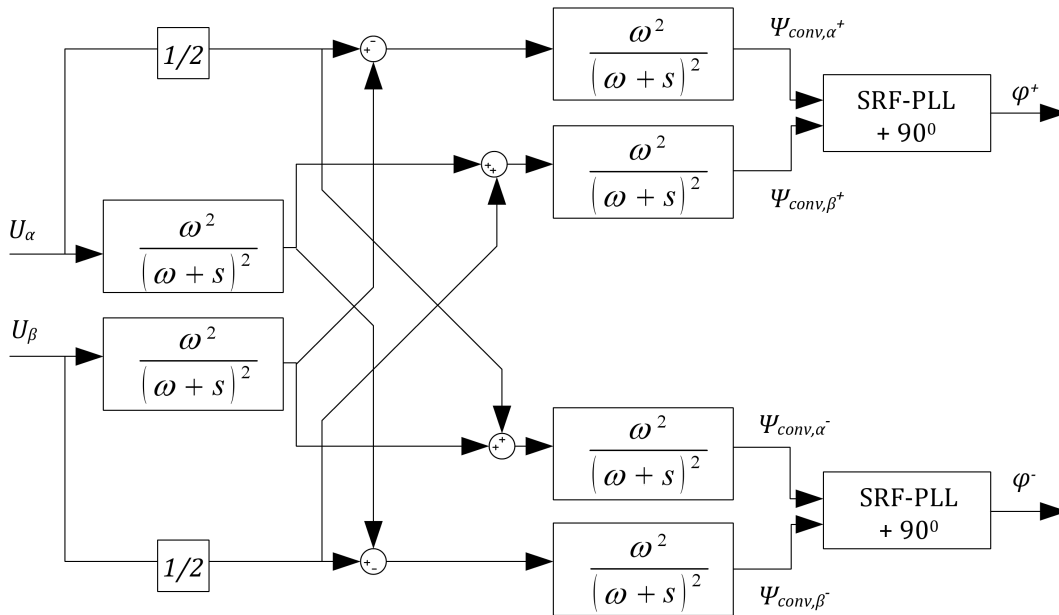

Fig. 6. Block diagram of Dual Virtual Flux PLL (DVF-PLL)

Basically, the VF was used as grid voltage estimator. Integration results in attenuation of higher harmonics. Then, by employing *arctan*, VF is used to phase angle calculations. Authors decided to introduce VF into basic schema SRF-PLL due to improve performance and unify selected to review algorithms.

In practice, a pure integrator for estimation VF cannot be used due to DC offset, which leads output signal to saturation. A sufficient solution is to use Low Pass Filter (LPF) with bandwidth set lower than grid frequency [41]. The drawback of VF is slower response in time domain than PLL presented above.

The solution of this problem is Dual Virtual Flux (DVF), presented in [42, 43]. The DVF gives much faster time response, precise phase shift and small amplitude attenuation. Cascading two adaptive LPFs, with a cut-off frequency equals 50 Hz, produces exactly 90° phase shift and 50% of original amplitude. Additionally used decoupling network gives opportunity to calculate two phase signal: positive and negative. The complete block of DVF-PLL is shown in Fig. 6.

## 7. Results

After theoretical analysis of three PLL algorithms, simulation process was carried out in Matlab Simulink environment. Discrete implementation of DSOGI-PLL, DSRF-PLL and DVF-PLL was indispensable. During simulation process, operating of PLLs in presence of voltage dips, higher harmonics and frequency jumps was verified. In simulated oscillograms all variations occurs at 0.2 s.

**7.1. Positive and negative sequence estimation during single phase 50% voltage dip.** Firstly, the positive and negative sequence estimation was tested. Grid voltage was distorted by

single phase 50% depth dip. In a general case the multiphase sinusoidal waveforms can be represented by superposition of positive, negative and zero sequence [14]. With symmetrical sinusoidal voltage only positive sequence is present. During voltage dip one or more phase voltages drop or phase shift can appear, introducing negative sequence [30]. In the Synchronous Reference Frame (SRF) it appears as oscillation with doubled grid frequency. The zero sequence does not appear in three-wire connection.

During single phase dip the negative sequence of voltage occurs, what influences voltages in all coordinates: *abc* (Fig. 7a), *αβ* (Fig. 7b) and *dq* (Fig. 8). In *αβ* plane, the grid voltage during dip is no longer circular but becomes elliptical. Owing to employed sequence estimators: DSOGI (Fig. 8a), DSRF (Fig. 8b), DVF (Fig. 8c), *αβ* plane in every case remains circular. The visibility of distortions in *αβ* plane is poor, better results gives signals presented as DC quantities in SRF. Hence, for further verification, signals in SRF will be compared.

In the SRF sinusoidal signals become DC quantities, which greatly simplifies system analysis and also converter control algorithm. The appearance of negative sequence introduces 100 Hz oscillations (Fig. 9a) both in *d* and *q* axes. Due to use of symmetrical components estimators, voltage in *dq* remains DC quantity. Process of estimation generates transient state, what leads to overshoot. The larger overshoot in *U<sub>q</sub>* (10.5 V) is in DSOGI. Additionally, the DSOGI does not assure protection from negative sequence and *U<sub>q</sub>* is still oscillating. Remaining DSRF and DVF do not oscillate. In the DSRF's the overshoot is 10 V and DVF's is 8 V. The settling time *t<sub>s</sub>* of estimated voltages is comparable. The fastest of algorithms is DVF and the THD factor of sinus of estimated phase angle is negligible.

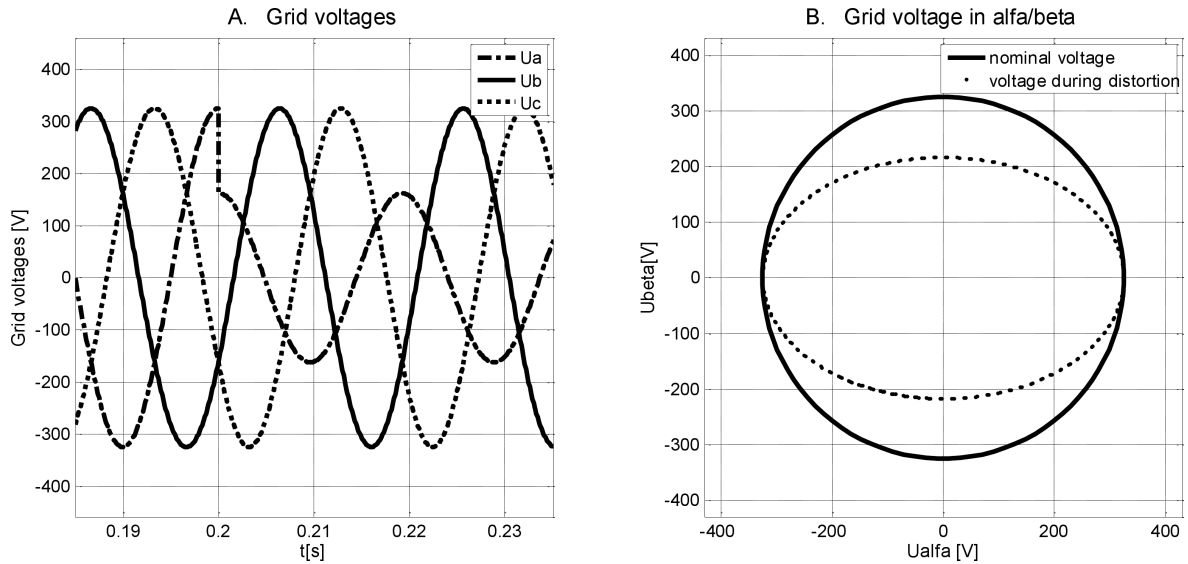

Fig. 7. Nominal grid voltage and voltage during single phase 50% voltage dip (a) in abc; (b) in  $\alpha\beta$

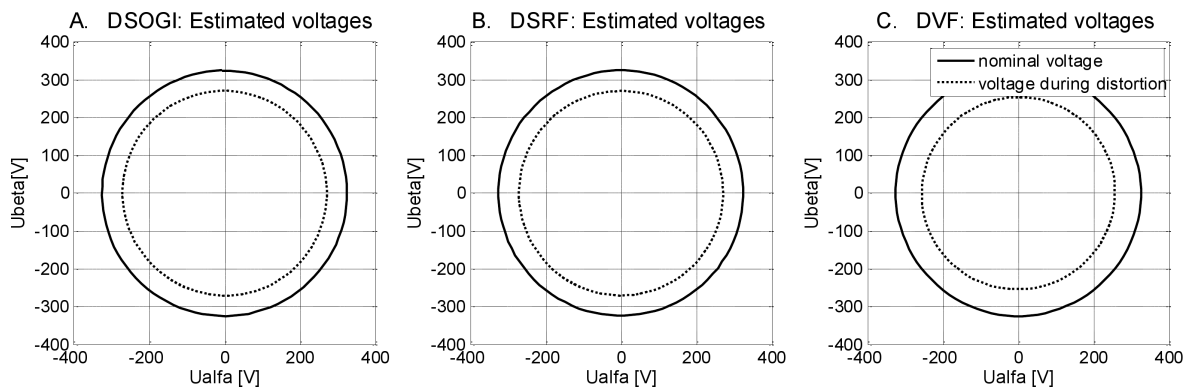

Fig. 8. Nominal voltage and estimated voltage during 50% single phase voltage dip in  $\alpha\beta$ : a) DSOGI; b) DSRF; c) DVF

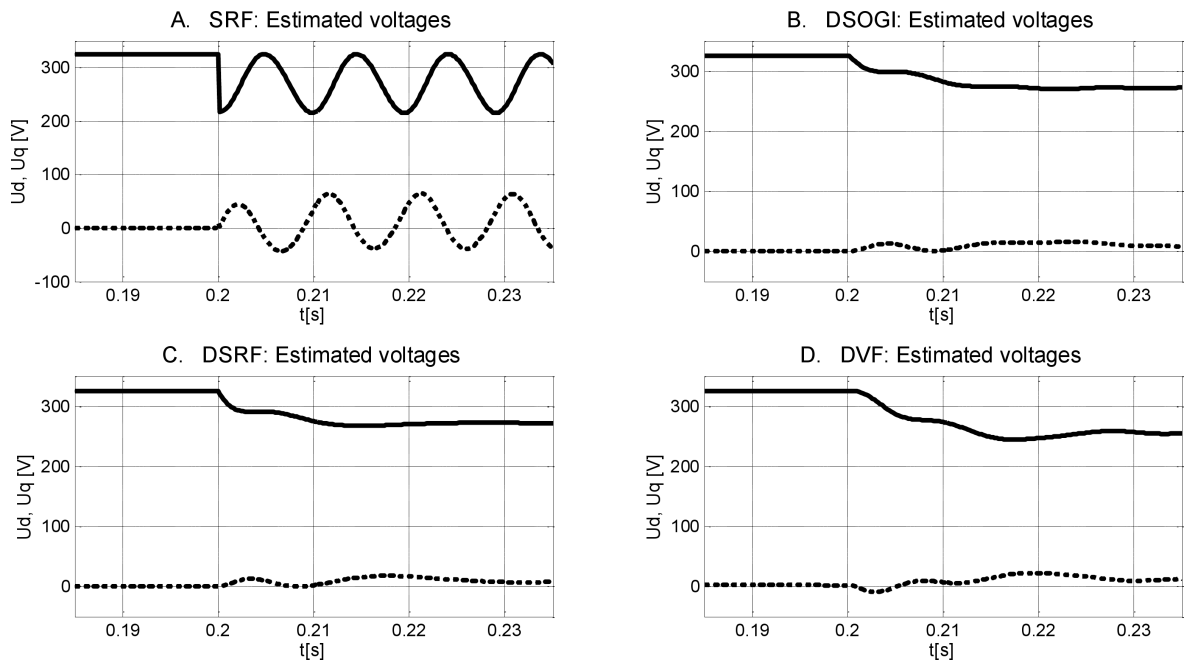

Fig. 9. Nominal voltage (a) and estimated voltage during 50% voltage dip in  $dq$  (b) DSOGI; (c) DSRF; (d) DVF

**7.2. Phase estimation during two phase 50% voltage dip.**

The next step was testing phase estimation. Here, sequence estimators are connected to the SRF-PLL, forming DSOGI-PLL, DSRF-PLL and DVF-PLL. Phase estimators, apart from voltages in different coordinates, generate both phase and angular frequency of voltage.

In 0.2 s two phase 50% depth voltage dip occurs (Fig. 10a) and  $\alpha\beta$  plane is more flattened comparing to single phase dip (Fig. 10b). The presence of negative sequence causes oscilla-

tion of voltages, estimated in the simplest way by basic SRF-PLL (Fig. 11a). Als, oscillations occurs in angular frequency estimated by DSOGI-PLL (Fig. 11b).

The grid voltage phase angle during two phase voltage dip is distorted by 2<sup>nd</sup> harmonic, which appears as oscillations and displacement (Fig. 12). The phase angles estimated by DSOGI-PLL, DSRF-PLL and DVF-PLL are not shifted and are stable. The THD of voltage generated by estimators is negligible.

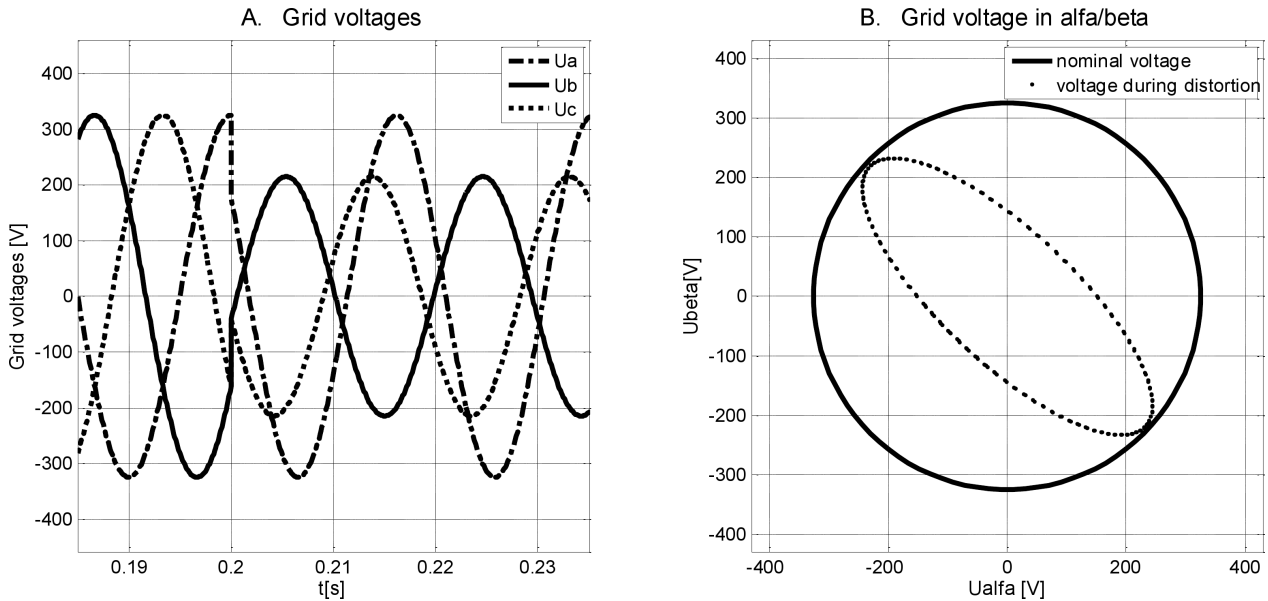

Fig. 10. Nominal grid voltage and voltage during two phase 50% voltage dip: a) in  $abc$ ; b) in  $\alpha\beta$

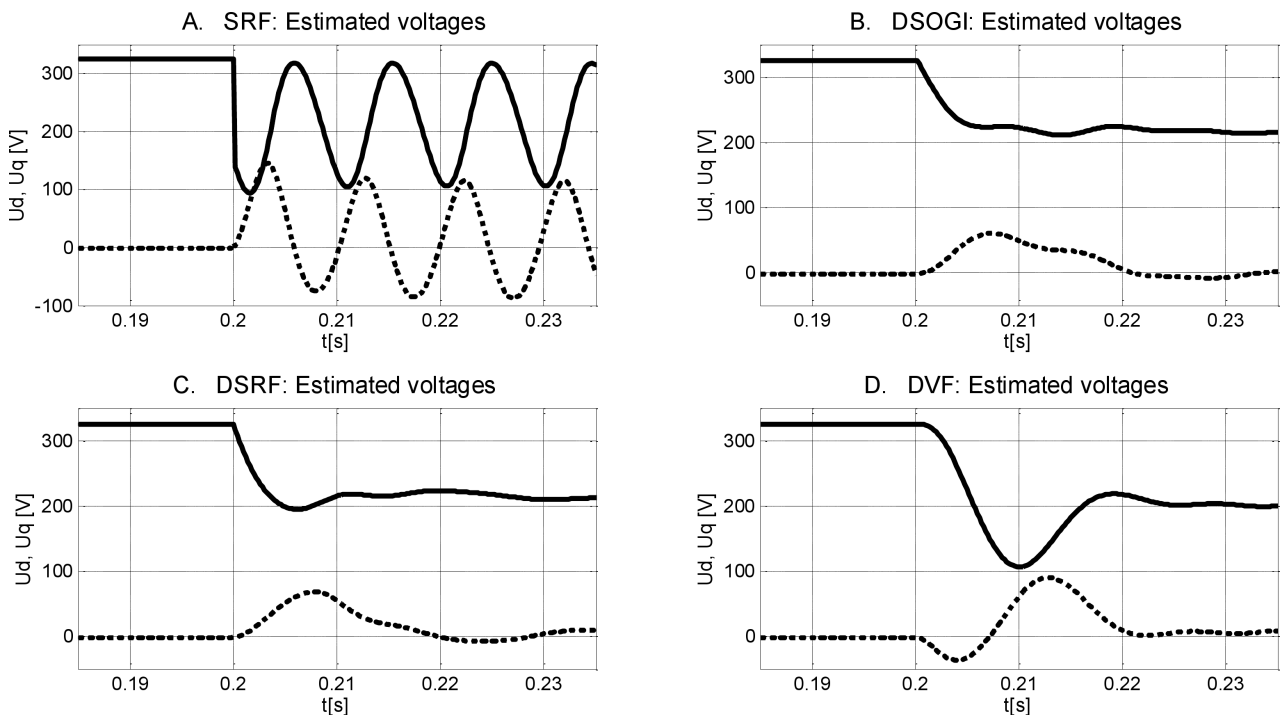

Fig. 11. Grid voltage voltages during two phase 50% voltage dip estimated by: a) SRF-PLL; b) DSOGI-PLL; c) DSRF-PLL; d) DVF-PLL



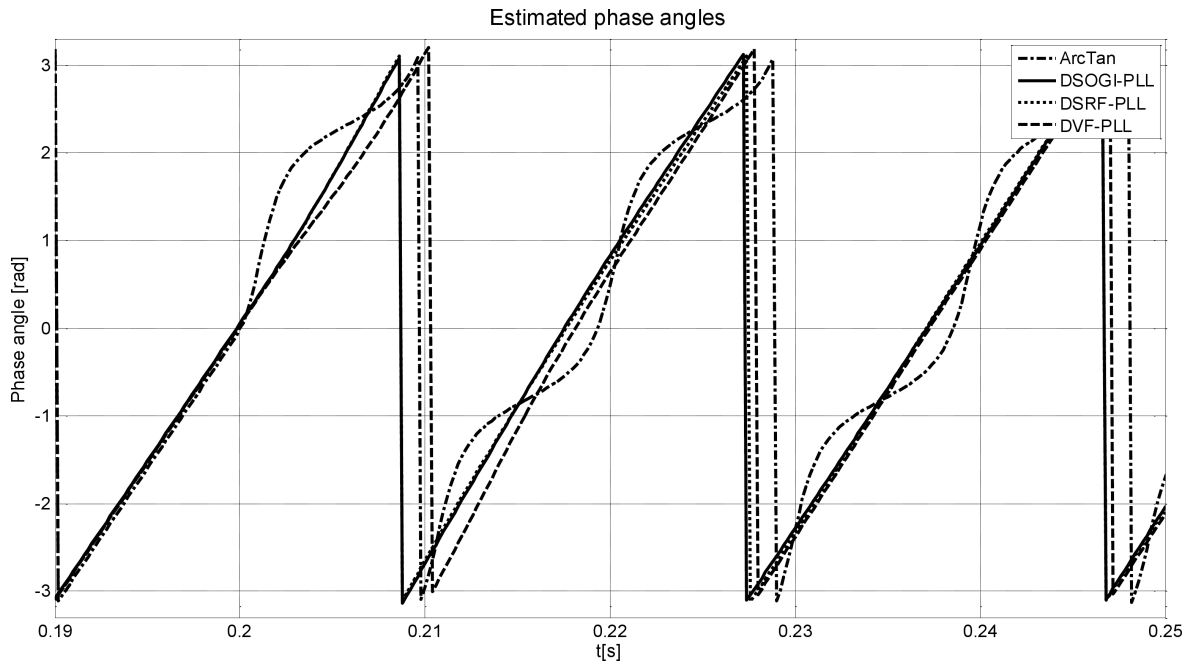

Fig. 12. Estimated phase angle

**7.3. Phase estimation for 15% content of 5<sup>th</sup> harmonic.**

The next test of phase estimator was adding 15% content of 5th harmonic to the grid voltage. The distorted grid voltage in *abc* is presented in Fig. 13a and in  $\alpha\beta$  I presented in Fig. 13b.

The angular frequency of grid voltage estimated by the basic SRF-PLL is oscillating with amplitude 50 V. The smallest oscillations and the fastest setting time is in the angular frequency estimated by DVF-PLL.

Estimated phase angle in every case is stable but the high-

est THD generates DSRF-PLL and the smallest in DVF-PLL. The THD of phase angle filtrated by PLL algorithms is in all cases below 1% (Fig. 15).

The tests were also carried out during frequency jump from 50 Hz to 47 Hz. The frequency jump does not distort phase angle or angular speed so heavily as it takes place during voltage dips or higher harmonics. Therefore, the results of operating estimators during frequency jump have not been presented in this paper.

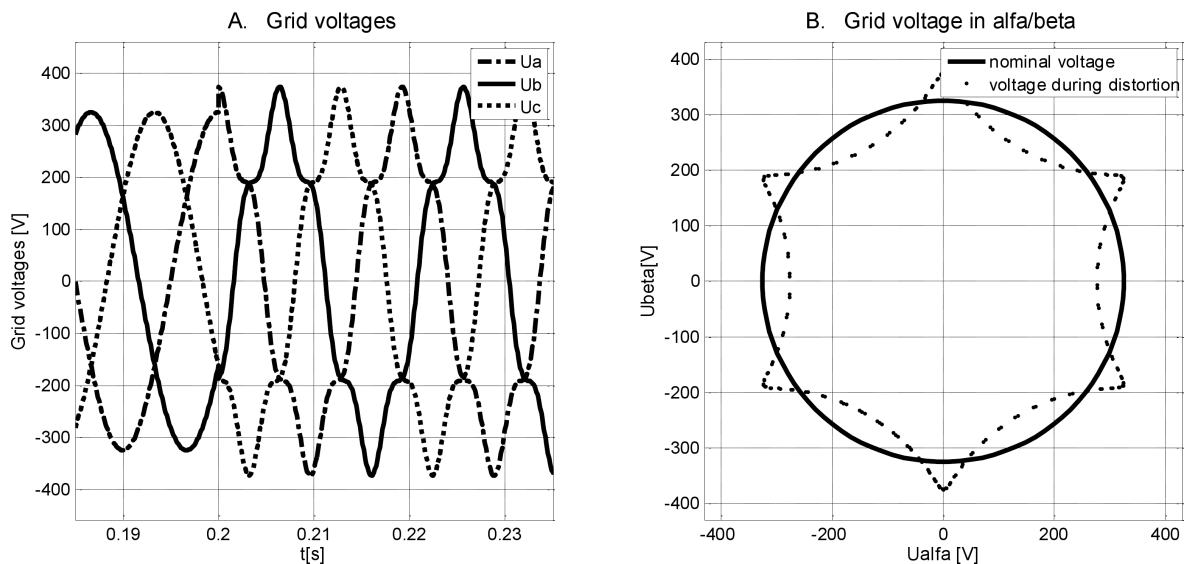

Fig. 13. Nominal grid voltage and voltage during 15% content of 5th harmonic: a) in *abc*; b) in  $\alpha\beta$

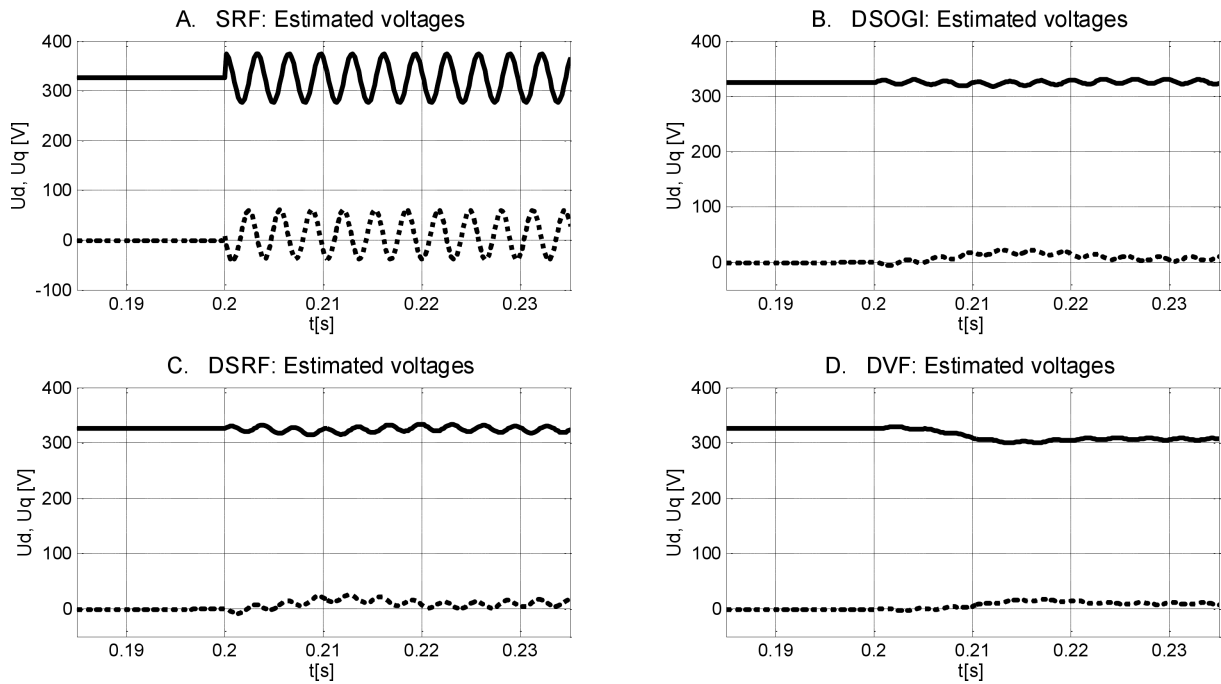

Fig. 14. Grid voltage voltages angular frequency during 15% content of 5th harmonic: a) SRF-PLL; b) DSOGI-PLL; c) DSRF-PLL; d) DVF-PLL

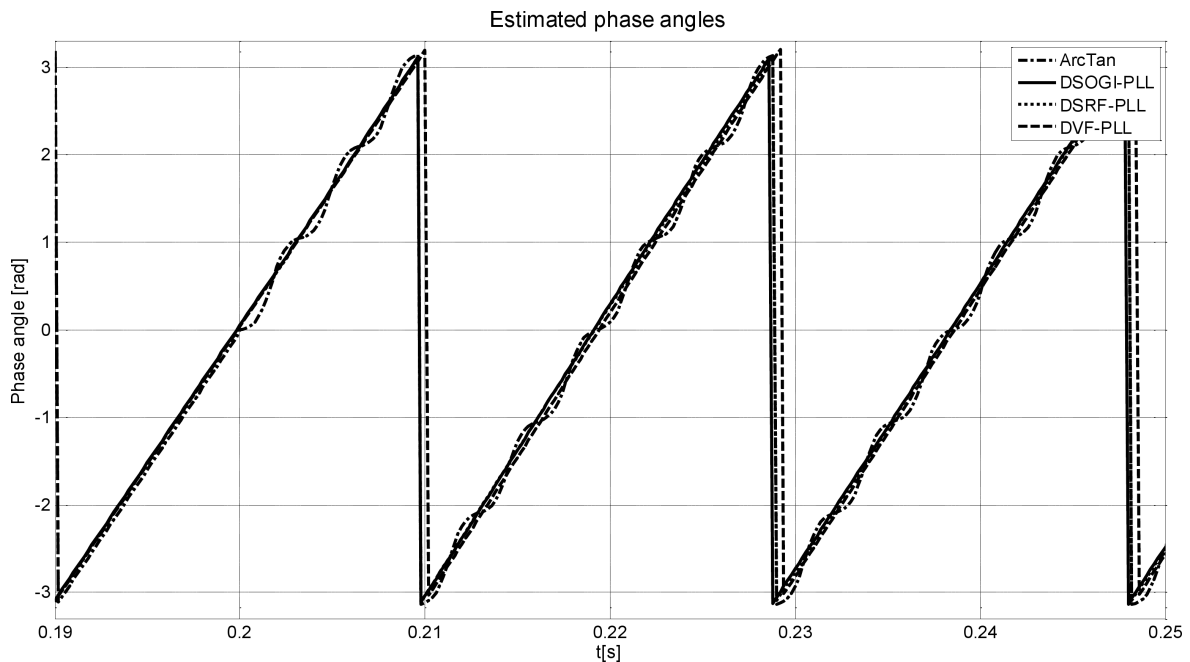

Fig. 15. Estimated phase angle during 15% content of 5th harmonic

**7.4. Experimental results.** Experimental verification has been made on laboratory platform shown in Fig. 16, described in [44]. Distorted grid voltage was simulated using California Instruments 5001iX programmable source. Presented PLL algorithms have been implemented on dSPACE 1005 platform. Measurement equipment included Tektronix 3034B scope.

During the experimental verification of system, operations under single phase voltage dip and 10% content of 5<sup>th</sup> harmonic were verified. In Fig. 17a the basic arcus tangens PLL is distorted by 2<sup>nd</sup> harmonic, which occurs due to existence

of negative component. In Fig. 17b DSOGI-PLL is operating properly during the same voltage conditions and estimating phase angle of positive sequence voltage. The results of experimental tests under appearance of 5<sup>th</sup> harmonic are presented in Fig. 18a (arcus tangens PLL) and Fig. 18b. (DSOGI PLL). Again, DSOGI-PLL proved to be more resistant to voltage distortions. Other PLL algorithms (DSRF-PLL and DVF-PLL) with sequence estimation provide similar results. The differences in operations of three PLL algorithm with sequence estimation in experimental results is imperceptible.

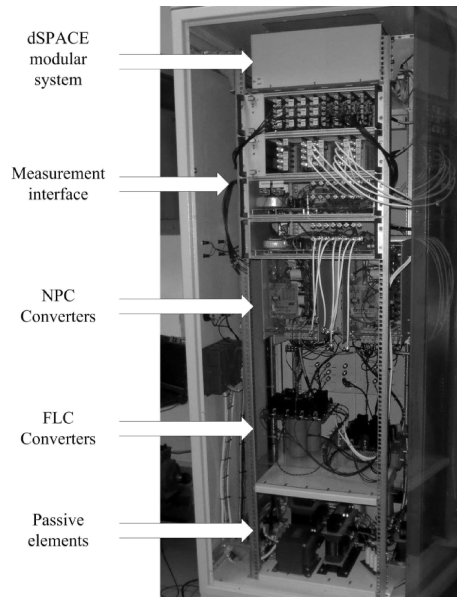

Fig. 16. Laboratory setup

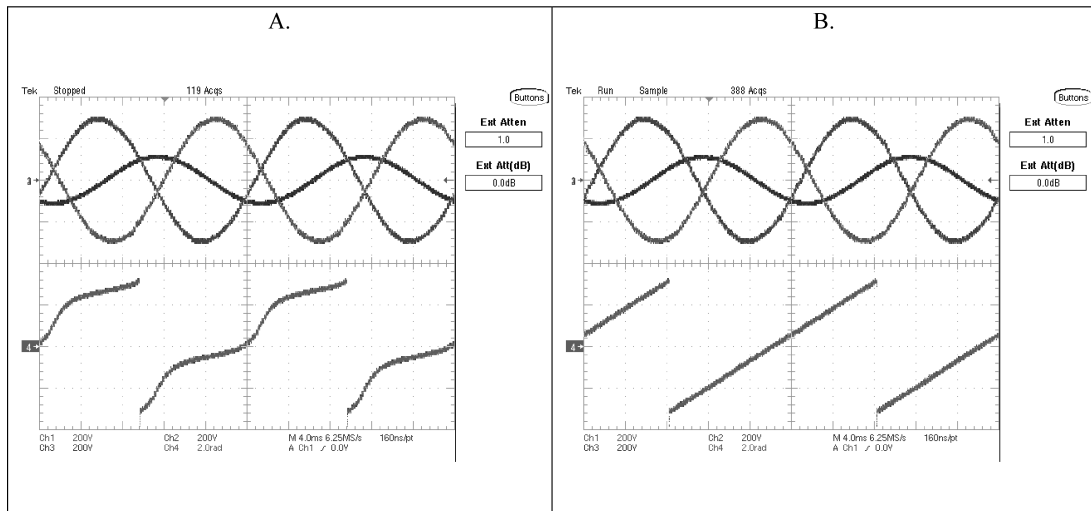

Fig. 17. Experimental results: system operating under single phase voltage dip a) arcus tangens PLL; b) DSOGI-PLL

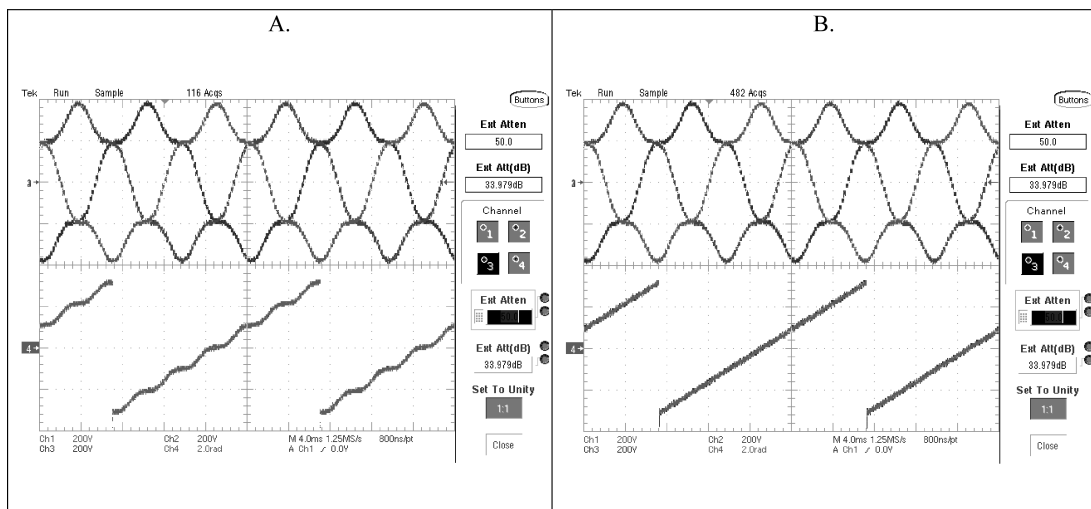

Fig. 18. Experimental results: system operating under 10% content of 5th harmonic a) arcus tangens PLL; b) DSOGI-PLL

## 8. Conclusions

This paper presents the review and comparison of PLL algorithms. Three groups of PLL algorithms are distinguished, due to signals transformations: basic in  $abc$ ,  $\alpha\beta$  and in  $dq$  coordinates. To evaluate best PLL algorithm, a set of criterions, based on DC quantities in  $dq$  axes, were proposed (overshoot and settling time of voltage  $U_q$  and angular speed error  $\Delta\omega$ , THD content in phase angle).

During tests, operation of three selected algorithms (DSOGI-PLL, DSRF-PLL and DVF-PLL) under grid voltage distortions is analyzed. The results for 50% two phase voltage dip (DIP) and 15% content of 5<sup>th</sup> harmonic (HAR.) are summarized in Table 2. The oscillations in signals are marked with letter  $O$ .

Table 2  
Test results of different PLLs under voltage dips (DIP) and higher harmonics (HAR.)

Parameters	Remarks	Method		
		DSOGI-PLL	DSRF-PLL	DVF-PLL
Overshoot of estimated voltage $U_q$ [V]	DIP	10 (O=0.9)	7.9 (O=0.03)	6.25
	HAR.	6.3 (O=4)	9.1 (O=6.6)	3.55 (O=1.8)
Overshoot of angular speed error $\Delta\omega$ [rad/s]	DIP	10.6 (O=0.8)	-12.1 (O=0.02)	-11.3
	HAR.	6.3 (O=4)	9.2 (O=6.5)	3.6 (O=2.8)
Settling time of $U_q$ [s]	DIP	0.09	0.07	0.03
	HAR.	0.09	0.06	0.04
Settling time of $\Delta\omega$ [s]	DIP	0.08	0.06	0.04
	HAR.	0.08	0.07	0.04
THD of sinus of phase angle [%]	DIP	0.12	0.04	0.03
	HAR.	0.15	0.25	0.07

During tests, the DSOGI-PLL occurred the worst one among three chosen algorithms. It gives the largest oscillations in positive voltage component and angular speed, during existence of negative component. Also, its settling time was the longest one. The advantage of DSOGI-PLL is the smallest overshoot in comparison to the fastest DVF-PLL or DSRF-PLL. The THD of estimated phase angle is negligible in all three algorithms (less than 1%).

Under higher harmonic appearance all three PLL algorithms generate oscillations (the biggest one DSRF-PLL, the smallest one DVF-PLL). The THD factor of three phase angle was attenuated (below 1%). In this case, the fastest was again the DVF-PLL and the largest overshoot occurs at the DSRF-PLL. The frequency jump is less heavy to compensate than dips or higher harmonics for all PLL algorithms. The overshoot is significantly smaller. The fastest algorithm was the DVF-PLL with result 0.03 s.

The best results under voltage dips, higher harmonics or frequency jump appearance was obtained using DVF-PLL. Among its advantages there are high dynamics and high sever-

ity to grid voltage distortions. The disadvantage of DVF-PLL is overshoot during transient state, which is quickly attenuated by filters. The DSOGI-PLL is sensitive to voltage dips and DSRF-PLL to higher harmonics.

**Acknowledgements.** This work has been supported by the European Union in the framework of European Social Fund through the Warsaw University of Technology Development Programme.

## REFERENCES

- [1] I. Wasiak, Z. Hanzelka, "Integration of distributed energy sources with electrical power grid", *Bull. Pol. Ac.: Tech.* 57 (4), 297–309 (2009).
- [2] G. Radmoski, "Control and modulation methods of voltage source converter", *Bull. Pol. Ac.: Tech.* 57 (4), 323–336 (2009).
- [3] M.P. Kazmierkowski, R. Krishnan, and F. Blaabjerg, *Control in Power Electronics: Selected Problems*, Academic Press, 2002
- [4] A. Sikorski and A. Kuzma, "Cooperation of induction squirrel-cage generator with grid connected AC-DC-AC converter", *Bull. Pol. Ac.: Tech.* 57 (4), 317–322 (2009).
- [5] R. Teodorescu, M. Lissere, and P. Rodriguez, *Grid Converter for Photovoltaic and Wind Power Systems*, IEEE-Wiley, New York, 2011.
- [6] G. Benysek, M.P. Kazmierkowski, J. Popczyk, and R. Strzelecki, "Power electronic systems as crucial part of a smart grid infrastructure – a survey", *Bull. Pol. Ac.: Tech.* 59 (4), (2011).
- [7] G. Benysek, "Improvement in the efficiency of the distributed power systems", *Bull. Pol. Ac.: Tech.* 57 (4), 369–374 (2009).
- [8] G.C. Hsieh and J.C. Hung, "Phase-locked loop techniques – a survey", *IEEE Trans. on Industrial Electronics* 43 (6), 609–615 (1996).
- [9] P. Rodríguez, A. Luna, M. Ciobotaru, R. Teodorescu, and F. Blaabjerg, "Advanced grid synchronization system for power converters under unbalanced and distorted operating conditions", *Proc. IEEE-IECON* 1, 5173–5178 (2006).
- [10] A. Timbus, R. Teodorescu, F. Blaabjerg, and M. Liserre, "Synchronization methods for three phase distributed power generation system. an overview and evaluation", *Proc. IEEE-PESC* 1, 2474–2481 (2005).
- [11] F. Freijedo, J. Doval-Gandoy, O. Lopez, and E. Acha, "A generic open-loop algorithm for three-phase grid voltage/current synchronization with particular reference to phase, frequency, and amplitude estimation", *Trans. Power Electronics* 24 (1), 94–107 (2009).
- [12] A. Luna, J. Rocabert, G. Vazquez, P. Rodriguez, R. Teodorescu, and F. Corcoles, "Grid synchronization for advanced power processing and FACTS in wind power systems", *Proc. IEEE-ISIE* 1, 2915–2920 (2010).
- [13] Ch.L. Fortescue, "Method of symmetrical coordinates applied to the solution of polyphase networks", *AIEE Trans.* 37, 1027–1140 (1918).
- [14] W.V. Lyon, *Application of the Method of Symmetrical Components*, McGraw-Hill, New York, 1937.
- [15] G.F. Franklin, D.J. Powell, and A. Emami-Naeni, *Feedback Control of Dynamic Systems*, Prentice Hall, New Jersey, 2002.
- [16] O. Vainio, S. Ovaska, and M. Polla, "Adaptive filtering using multiplicative general parameters for zero-crossing detection", *IEEE Trans. on Indust. Electronics* 50 (6), 1340–1342 (2003).
- [17] M. Mojiri, D. Yazdani, and A. Bakhshai, "Robust adaptive frequency estimation of three-phase power systems", *IEEE*

- Trans. on Instrumentation and Measurement* 59 (7), 1793–1802 (2010).
- [18] A. Nicastrì and A. Nagliero, “Comparison and evaluation of PLL techniques for the design of the grid-connected inverter systems”, *Proc. IEEE-ISIE* 1, 3865–3870 (2010).
- [19] A. Timbus, M. Liserre, R. Teodorescu, P. Rodriguez, and F. Blaabjerg, “PLL algorithm for power generation systems robust to grid voltage faults”, *Proc. IEEE-PESC* 1, 1–7 (2007).
- [20] M. Saitou, N. Matsui, and T. Shimizu, “A control strategy of single-phase active filter using a novel d-q transformation”, *Proc. IEEE-IAS* 1, 1222–1227 (2003).
- [21] S. Luo and Z. Hou, “An adaptive detecting method for harmonic and reactive currents”, *IEEE Trans. on Indust. Electronics* 42 (1), 334–338 (1995).
- [22] H. Yoo, J. Kim, and S. Sul, “Sensorless operation of PWM rectifier for distributed generation”, *IEEE Trans. on Power Electronics* 22 (3), 1014–1018 (2007).
- [23] A. Nicastrì and A. Nagliero, “Comparison and evaluation of the PLL techniques for design of grid-connected inverter systems”, *Proc. IEEE-ICECS* 1, 3865–3870 (2008).
- [24] E. Robles, S. Ceballos, J. Pou, J. Zaragoza, and I. Gabiola, “Grid synchronization method based on quasi-ideal low pass filter stage and phase locked loop”, *Proc. IEEE-PESC* 1, 4056–4061 (2008).
- [25] Y. Wang and Y. Li, “Analysis and digital implementation of cascaded delayed-signal-cancellation PLL”, *Trans. on Power Electronics* 26 (4), 1067–1080 (2011).
- [26] X. Yuan, W. Merk, H. Stemmler, and J. Allmeling, “Stationary-frame generalized integrators for current control of active power filters with zero steady-state error for current harmonics of concern under unbalanced and distorted operating conditions”, *IEEE Trans. on Indust. Applications* 38 (2), 2143–2150 (2002).
- [27] O. Krievs, I. Steiks, and L. Ribickis, “A PLL scheme for synchronization with grid voltage phasor in active power filter systems”, *Sci. J. Riga Technical University: Power and Electrical Eng.* 27, 133–136 (2010).
- [28] F. Freijedo, A. Yepes, O. Lopez, A. Vidal, and J. Doval-Gandoy, “Three-phase PLLs with fast postfault retracking and steady-state rejection of voltage unbalance and harmonics by means of lead compensation”, *Trans. on Power Electronics* 26 (1), 85–97 (2011).
- [29] P. Rodríguez, J. Pou, J. Bergas, I. Candela, R. Burgos, and D. Boroyevich, “Double synchronous reference frame PLL for power converters control”, *Proc. IEEE-PESC* 1, 584–592 (2005).
- [30] M. Bobrowska-Rafal, K. Rafal, G. Abad, and M. Jasinski, “Control of PWM rectifier under grid voltage dips”, *Bull. Pol. Ac.: Tech.* 57 (4), 337–343 (2009).
- [31] P. Rodriguez, A. Luna, R. Teodorescu, and F. Blabjerg, “Grid synchronization of wind turbine converters under transient grid faults using a double synchronous reference frame PLL”, *Proc. Energy Conf.* 1, 1–8 (2008).
- [32] T. Le, “Kompensation schnell veränderlicher Blindströme eines Drehstromverbrauchers”, *EtzArchiv, Bd. 11 H, 8* (1989).
- [33] P. Xiao, K.A., Corzine, and G. Kumar, “Multiple reference frame-based control of three-phase pwm boost rectifier under unbalanced and distorted input conditions”, *IEEE Trans. on Power Electronics* 23 (4), 2006–2017 (2008).
- [34] X. Fang, Y. Wang, M. Li, K. Wang, and W. Lei, “A novel PLL for grid synchronization of power electronic converters in unbalanced and variable-frequency environment”, *Proc. IEEE-PEDG* 1, 466–471 (2010).
- [35] J. Svensson, “Synchronization methods for grid-connected voltage source converters”, *IEEE Proc. Generation, Transmission and Distribution* 148 (3), 229–235 (2001).
- [36] H. Kim, S. Lee, and S. Sul, “Reference wave generator in dynamic voltage restorer by use of PQR power theory”, *Proc. IEEE-APEC* 1, 1452–1457 (2004).
- [37] P. Rodriguez, R. Teodorescu, I. Candela, A. Timbus, M. Liserre, and F. Blaabjerg, “New positive-sequence voltage detector for grid synchronization of power converters under faulty grid conditions”, *Proc. IEEE-PESC* 1, 1–7 (2006).
- [38] S. Bhattacharya, A. Veltman, D.M. Divan, R.D. Lorenz, “Flux-based active filter controller”, *IEEE Trans. Indust. Applications* 32 (3), 491–502 (1996).
- [39] M. Chandorkar, “New control techniques for inverter flux”, *Proc. IEEE-IAS* 1, 86–93 (1999).
- [40] M. Malinowski, W. Szczygiel, M.P. Kazmierkowski, and S. Bernet, “Sensorless operation of active damping methods for three-phase PWM converters”, *Proc. IEEE-ISIE* 1, 775–780 (2005).
- [41] W. Gullvik, L. Norum, and R. Nilsen, “Active damping of resonance oscillations in LCL-filters based on virtual flux and virtual resistor”, *Proc. IEEE-EPE* 1, 1–10 (2007).
- [42] M. Malinowski, “Sensorless control strategies for three-phase PWM rectifiers”, *Ph.D. Thesis*, Warsaw University of Technology, Warsaw, 2001.
- [43] A. Kulka, “Sensorless digital control of grid connected three phase converters for renewable sources”, *Ph.D. Thesis*, Norwegian University of Science and Technology, Trondheim, 2009.
- [44] K. Rafal, M. Bobrowska-Rafal, S. Piasecki, and M. Jasinski, “Coordinated control of grid-connected three-level NPC converter under distorted grid voltage”, *Proc. IEEE-ISIE* 1, 1011–1016 (2011).