

Dead-beat and reaching-law-based sliding-mode control of perishable inventory systems

P. IGNACIUK* and A. BARTOSZEWICZ

Institute of Automatic Control, Technical University of Lodz, 18/22 Stefanowskiego St., 90-924 Łódź, Poland

Abstract. In this paper we consider the problem of efficient control of inventory systems with perishable goods. In the analyzed setting the deteriorating stock at a distribution center used to fulfill unknown, time-varying demand is replenished with delay from a supply source. The challenging issue is to achieve the high service level with minimum costs when the replenishment orders are procured with lead-time delay spanning multiple review periods. On the contrary to the typical heuristic approaches, we apply formal methodology based on discrete-time sliding-mode (SM) control. The proposed SM controller with the sliding plane selected for a dead-beat scheme ensures that the maximum service level is obtained in the system with arbitrary delay and any bounded demand pattern. In order to account for the supplier capacity limitations in the systems with input constraints, we also develop an alternative control strategy based on reaching law. Both controllers achieve a given service level with smaller holding costs and reduced order-to-demand variance ratio as compared to the classical order-up-to policy.

Key words: sliding-mode control, inventory control, perishable inventories, discrete-time control systems.

1. Introduction

An appropriate inventory management policy is crucial for efficient operation of production and logistic systems [1]. Due to the similarity between the considered class of systems and engineering processes, it is a natural choice to apply control-theoretic methods in the design and analysis of strategies governing the flow of goods. However, it follows from the extensive review papers documenting the research work in the field [2–7] that certain areas of inventory control are not sufficiently addressed at the formal design level. The deficiency of application of systematic control approaches concerns in particular a large and very important class of problems related to the management of perishable commodities. Indeed, many products, such as food, drugs, gasoline, etc., lose market value over time, deteriorate due to the changes in chemical structure, or even become obsolete (as for instance the components in the high-tech industry). The primary difficulty in developing control schemes for perishable inventories is the enlarged state space required for conducting the exact analysis of product lifetimes. The situation aggravates when the product demand varies rapidly in subsequent review periods and inventories are replenished with nonzero delay, which frequently happens in modern supply chains. In such circumstances, in order to meet the service level requirements at low costs, when making the ordering decision it is necessary not only to account for the demand during procurement latency but also for the stock deterioration in that time.

There are very few successful design examples based on formal control methods for perishable inventory systems. Bensoussan et al. [8] considered a continuous-time system with deterministic and stochastic deterioration rates and ze-

ro lead-time. The authors of [8] used distributed parameter systems theory to find a quadratically-optimal replenishment rule. However, the analytical solution can be determined only provided that demand is known. In papers [9, 10], linear-quadratic optimization is performed for an undelayed process. Rodrigues and Boukas [11] design a piecewise affine control law for a production system with deteriorating on-hand inventory and zero lead-time. In [12], a robust controller for the continuous system with uncertain processing time and delay in control is designed by minimizing an H_∞ -norm. However, the implementation of the strategy proposed in [12] requires numerical procedures for obtaining the control law parameters which limits its tractability at the analytical level.

In this paper, we apply control-theoretic methodology to develop a new supply policy for periodic-review inventory systems with perishable goods. In the considered systems, the on-hand stock at a distribution center is used to fulfill an unknown, time-varying demand placed by customers. The stock deteriorates exponentially at a constant rate and is replenished with delay from a remote supply source. We assume that delay (lead-time) can span multiple review periods. The design objective is to obtain high service level with minimum on-hand inventory. For this purpose, we propose discrete-time sliding-mode (SM) control, which is well known to be efficient and robust regulation technique [13–19]. Since a proper choice of the switching plane is the key part of the design of SM controllers [20–25], in this work, we determine the plane parameters for a dead-beat scheme. In this way we obtain fast response to the changes in demand and the minimum stock level. In contrast to the majority of solutions reported previously in literature for perishable goods, we adopt a formal design approach. Moreover, as opposed to our earlier

*e-mail: przemyslaw.ignaciuk@p.lodz.pl

works devoted to the traditional inventory systems (i.e. the systems with nondeteriorating stock) [26, 27], we explicitly consider here the decaying inventories, which constitute a different and more complex class of objects in supply chain dynamics [4]. We solve the design problem analytically and obtain the control algorithm expressed in a closed-form. The closed-form solution allows us to define and strictly prove a number of advantageous properties of the proposed control scheme. In particular, we show that under the proposed policy the available stock is never entirely depleted despite unpredictable demand variations, which guarantees the maximum service level (full demand satisfaction from the readily available resources). We also specify a precise value of the storage space which should be reserved at the distribution center to always accommodate all the incoming shipments. This means that the potential necessity of expensive emergency storage outside the company premises is eliminated. Finally, we show that the order quantities generated by the presented controller are always nonnegative and bounded, which is required for the practical implementation of a replenishment rule. Since a dead-beat scheme typically generates large control signals in the initial phase of the control process which can be difficult to realize in practice due to supplier limitations, we propose another SM controller which allows for satisfying the input constraints without downgrading the system dynamics. The modified, nonlinear controller designed for the systems with supply source limitations is based on the concept of reaching law [28, 14–16] in the form proposed in [17]. The nonlinear controller is shown to provide a similar set of properties as the first, linear strategy, in particular it permits to achieve the maximum service level, yet it meets the input constraint imposed by a saturating supply source. We compare the proposed inventory policies with the classical order-up-to (OUT) one both analytically and in numerical

experiments. Our ordering rule outperforms the OUT policy in the analyzed system with perishable goods in terms of smaller storage space requirements, higher service level and reduced order-to-demand variance ratio.

The paper is organized in the following way. Firstly, in Sec. 2, we describe the model of inventory system with perishable goods. Then, in Sec. 3, we state the control problem and design a discrete-time SM controller with the sliding plane selected for a dead-beat scheme. We discuss its properties at the analytical level, and provide formal proofs of the important characteristics related to handling the flow of goods. Next, we present the SM controller design based on the concept of reaching law for the systems with input constraints. In Sec. 4, we compare our approach with the classical OUT policy. Finally, we present simulation results in Sec. 5, and give conclusions and managerial insights in Sec. 6.

2. Problem formulation

We analyze the inventory system, in which the stock used to satisfy an unknown, bounded, time-varying demand is replenished from a single supply source. Such setting, illustrated in Fig. 1, is frequently encountered in production-inventory systems where a common point (distribution center), linked to a factory or external, strategic supplier, is used to provide goods for another production stage or a distribution network. The task is to design a stable control strategy which will minimize lost service opportunities (occurring when only a part of the imposed demand can be satisfied from the stock available at the distribution center). The design procedure should on one hand explicitly consider the delay between placing of an order at the supplier and goods arrival at the center and on the other it should take into account the stock reduction of perishable commodities during this lead-time delay.

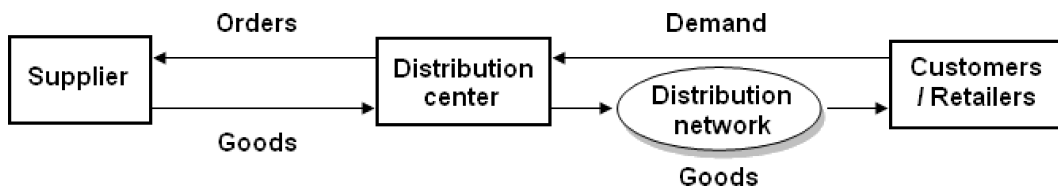
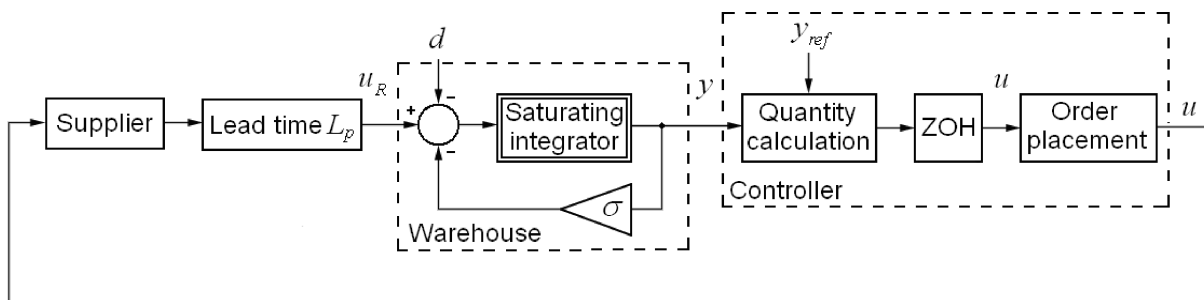

Fig. 1. Inventory system with a strategic supplier



ZOH – Zero Order Hold

Fig. 2. System model

The model of the analyzed periodic-review system is illustrated in Fig. 2. The stock replenishment orders u are issued at regular intervals kT , where T is the review period and $k = 0, 1, 2, \dots$. The order quantity is calculated on the basis of the current stock level $y(kT)$, the stock reference value y_{ref} , and the order history. Each non-zero order placed at the supplier is realized with lead-time L_p assumed to be a multiple of the review period, i.e. $L_p = n_p T$, where n_p is a positive integer. The saturating integrator in the internal loop represents the operation of accumulating the stock of perishables characterized by decay factor σ , $0 \leq \sigma < 1$. The imposed demand (the number of items requested from inventory in period k) is modeled as an *a priori* unknown, bounded function of time $d(kT)$, $0 \leq d(kT) \leq d_{max}$. Notice that this definition of demand is quite general and it accounts for any standard distribution typically analyzed in the considered problem. If there is a sufficient number of items in the warehouse to satisfy the imposed demand, then the actually met demand $h(kT)$ (the number of items sold to customers or sent to retailers in the distribution network) will be equal to the requested one. Otherwise, the imposed demand is satisfied only from the arriving shipments, and the additional demand is lost (we assume that the sales are not backordered, and the excessive demand is equivalent to a missed business opportunity). Thus,

$$0 \leq h(kT) \leq d(kT) \leq d_{max}. \quad (1)$$

For the considered system with perishable inventory the stock balance equation can be presented in the following form

$$y[(k+1)T] = \rho y(kT) + u_R(kT) - h(kT), \quad (2)$$

where $u_R(kT)$ is the order received in period k and $\rho = 1 - \sigma$ represents the fraction of stock which remains in the warehouse when inventory deteriorates at rate σ . For instance, if $\sigma = 0.05$, then 5% of the stock perishes in each review period and $\rho = 0.95$, or 95%, of the stock remains. Note that since $0 \leq \sigma < 1$ we have

$$0 < \rho \leq 1. \quad (3)$$

We assume that the warehouse is initially empty, i.e. $y(kT) = 0$ for $k < 0$, and the first order is placed at $kT = 0$. Because of lead-time delay, the first order arrives at the distribution center in period n_p , and $y(kT) = 0$ for $k \leq n_p$. We assume that the goods arrive at the distribution center new and deteriorate when kept in the on-hand stock. Taking into account the initial conditions and the fact that $u_R(kT) = u[(k - n_p)T]$, the stock level for any $k \geq 0$ may be calculated from the following equation

$$\begin{aligned} y(kT) &= \sum_{j=0}^{k-1} \rho^{k-1-j} u_R(jT) - \sum_{j=0}^{k-1} \rho^{k-1-j} h(jT) \\ &= \sum_{j=0}^{k-1} \rho^{k-1-j} u[(j - n_p)T] - \sum_{j=0}^{k-1} \rho^{k-1-j} h(jT) \quad (4) \\ &= \sum_{j=0}^{k-n_p-1} \rho^{k-n_p-1-j} u(jT) - \sum_{j=0}^{k-1} \rho^{k-1-j} h(jT). \end{aligned}$$

In order to save on notation in the remainder of the paper we will use k as the independent variable in place of kT .

The considered discrete-time system can also be described in the state space as

$$\begin{aligned} \mathbf{x}(k+1) &= \mathbf{A}\mathbf{x}(k) + \mathbf{b}u(k) + \mathbf{v}h(k), \\ y(k) &= \mathbf{q}^T \mathbf{x}(k), \end{aligned} \quad (5)$$

where $\mathbf{x}(k) = [x_1(k) \ x_2(k) \ \dots \ x_n(k)]^T$ is the state vector with $x_1(k) = y(k)$ representing the on-hand stock level in period k and $x_j(k) = u(k - n + j - 1)$ for any $j = 2, \dots, n$ equal to the delayed input signal u ; \mathbf{A} is $n \times n$ state matrix, \mathbf{b} , \mathbf{v} , and \mathbf{q} are $n \times 1$ vectors

$$\begin{aligned} \mathbf{A} &= \begin{bmatrix} \rho & 1 & 0 & \dots & 0 \\ 0 & 0 & 1 & \dots & 0 \\ \vdots & \vdots & \vdots & \ddots & \vdots \\ 0 & 0 & 0 & \dots & 1 \\ 0 & 0 & 0 & \dots & 0 \end{bmatrix}, & \mathbf{b} &= \begin{bmatrix} 0 \\ 0 \\ \vdots \\ 0 \\ 1 \end{bmatrix}, \\ \mathbf{v} &= \begin{bmatrix} -1 \\ 0 \\ \vdots \\ 0 \\ 0 \end{bmatrix}, & \mathbf{q} &= \begin{bmatrix} 1 \\ 0 \\ \vdots \\ 0 \\ 0 \end{bmatrix}, \end{aligned} \quad (6)$$

and the system order $n = n_p + 1 = L_p/T + 1$ depends on the review period and lead-time L_p . The desired system state is defined as

$$\mathbf{x}_d = \begin{bmatrix} x_{d1} \\ x_{d2} \\ \vdots \\ x_{dn-1} \\ x_{dn} \end{bmatrix} = \begin{bmatrix} 1 \\ 1 - \rho \\ \vdots \\ 1 - \rho \\ 1 - \rho \end{bmatrix} y_{ref}, \quad (7)$$

where y_{ref} denotes the reference stock level. Consequently, the control objective is to stabilize the first state variable (the on-hand stock) at the level y_{ref} . Since the goods perish at the rate $1 - \rho$ while kept in the warehouse, in order to maintain the on-hand stock at the desired level once y_{ref} is reached, it needs to be refilled from the incoming shipments equal to $(1 - \rho)y_{ref}$ in the steady state. Therefore, based on (2), all the state variables which represent the in-bound shipments x_2, \dots, x_n , should be equal to $(1 - \rho)y_{ref}$ once $y(k) = y_{ref}$. In a latter part of the paper we develop a control strategy which meets these design objectives. We will also show how to choose a suitable reference stock level such that a number of advantageous properties in the considered system is achieved.

3. Proposed inventory policy

In this section we design a controller for the inventory system with perishable goods (5)–(6) following a rigorous control approach based on discrete sliding modes. First, the design

procedure is conducted with the crucial part devoted to the selection of the sliding plane for a dead-beat scheme. The properties of the obtained control law are formulated and strictly proved. Next, in order to comply with possible supplier capacity limitations we propose another control structure, designed using reaching law approach. The improved nonlinear controller is shown to maintain the favorable properties of the linear dead-beat scheme, and additionally it ensures that input constraint is never violated. Finally, a comparison with the classical OUT policy is performed and the benefits of our approach are discussed at the analytical level.

3.1. Dead-beat SM controller design. Let us denote the closed-loop system error as $\mathbf{e}(k) = \mathbf{x}_d - \mathbf{x}(k)$. We introduce a sliding hyperplane described by the following equation

$$s(k) = \mathbf{c}^T \mathbf{e}(k) = 0, \quad (8)$$

where $\mathbf{c}^T = [c_1 \ c_2 \ \dots \ c_n]$ is the vector describing the sliding plane such that $\mathbf{c}^T \mathbf{b} \neq 0$. Substituting (5) into equation $\mathbf{c}^T \mathbf{e}(k+1) = 0$, the following feedback control law can be derived

$$u(k) = (\mathbf{c}^T \mathbf{b})^{-1} \mathbf{c}^T [\mathbf{x}_d - \mathbf{A} \mathbf{x}(k)]. \quad (9)$$

Using (6) we can rewrite (9) as

$$u(k) = c_n^{-1} \left\{ y_{ref} \left[c_1 + (1 - \rho) \sum_{j=2}^n c_j \right] - c_1 \rho x_1(k) - \sum_{j=2}^n c_{j-1} x_j(k) \right\}. \quad (10)$$

It is clear from (10) that the controller properties will be determined by an appropriate choice of the sliding plane parameters c_1, c_2, \dots, c_n . Since typically in inventory control it is favorable to provide fast reaction to varying market conditions, we intend to find such parameters of the plane which will allow for the error elimination in the smallest number of steps after a change in demand.

The characteristic polynomial of the closed-loop state matrix $\mathbf{A}_c = [\mathbf{I}_n - \mathbf{b}(\mathbf{c}^T \mathbf{b})^{-1} \mathbf{c}^T] \mathbf{A}$ with control (10) applied is determined as

$$\det(z \mathbf{I}_n - \mathbf{A}_c) = z^n + \frac{c_{n-1} - \rho c_n}{c_n} z^{n-1} + \dots + \frac{c_1 - \rho c_2}{c_n} z. \quad (11)$$

For a dead-beat control, the determinant $\det(z \mathbf{I}_n - \mathbf{A}_c)$ should be equal to z^n , which is satisfied when

$$\begin{aligned} c_{n-1} &= \rho c_n, & c_{n-2} &= \rho c_{n-1}, \dots, \\ c_2 &= \rho c_3, & c_1 &= \rho c_2. \end{aligned} \quad (12)$$

Having solved recursively this set of equations we obtain the following vector describing the parameters of the sliding plane

$$\mathbf{c}^T = [\rho^{n-1} \ \rho^{n-2} \ \rho^{n-3} \ \dots \ \rho \ 1] c_n. \quad (13)$$

Substituting (13) into (10), we get the control law

$$u(k) = y_{ref} - \rho^n x_1(k) - \sum_{j=2}^n \rho^{n-j+1} x_j(k) \quad (14)$$

From (6) the state variables x_j ($j = 2, 3, \dots, n$) may be expressed in terms of the control signal generated at the previous $n - 1$ samples as $x_j(k) = u(k - n + j - 1)$. Since $x_1(k) = y(k)$ and $n = n_p + 1$, we obtain

$$u(k) = y_{ref} - \rho^{n_p+1} y(k) - \sum_{j=k-n_p}^{k-1} \rho^{k-j} u(j). \quad (15)$$

3.2. Properties of the proposed controller. Further in this section the properties of inventory policy (15) will be given in a lemma and three theorems. The lemma and the first theorem show that the order quantities determined from the algorithm are always nonnegative and bounded, which is a crucial requirement for the practical implementation of any inventory management scheme. The second proposition specifies the warehouse capacity which needs to be provided to always accommodate the on-hand stock and the incoming shipments. Finally, the third theorem indicates how to select the reference stock level in order to ensure full demand satisfaction from the readily available resources.

First, notice that since it was assumed that $u(k < 0) = 0$, and $y(k \leq 0) = 0$, we have $u(0) = y_{ref}$. Afterwards, for $k \geq 1$, the control signal satisfies the relation given in the following lemma.

Lemma 1. If policy (15) is applied to control the flow of goods in system (5)–(6), then for any $k \geq 1$

$$u(k) = (1 - \rho) y_{ref} + \rho^{n_p+1} h(k - 1). \quad (16)$$

Proof. Substituting (4) into (15), we get

$$\begin{aligned} u(k) &= y_{ref} - \\ &- \rho^{n_p+1} \left[\sum_{j=0}^{k-n_p-1} \rho^{k-n_p-1-j} u(j) - \sum_{j=0}^{k-1} \rho^{k-1-j} h(j) \right] - \\ &- \sum_{j=k-n_p}^{k-1} \rho^{k-j} u(j) = y_{ref} - \sum_{j=0}^{k-n_p-1} \rho^{k-j} u(j) - \\ &- \sum_{j=k-n_p}^{k-1} \rho^{k-j} u(j) + \rho^{n_p} \sum_{j=0}^{k-1} \rho^{k-j} h(j) = \\ &= y_{ref} - \sum_{j=0}^{k-1} \rho^{k-j} u(j) + \rho^{n_p} \sum_{j=0}^{k-1} \rho^{k-j} h(j). \end{aligned} \quad (17)$$

For $k = 1$, it follows immediately from (17) that

$$\begin{aligned} u(1) &= y_{ref} - \rho u(0) + \rho \rho^{n_p} h(0) = \\ &= (1 - \rho) y_{ref} + \rho^{n_p+1} h(0), \end{aligned} \quad (18)$$

which shows that the lemma is indeed satisfied for $k = 1$. Let us assume that (16) is true for all integers up to some

$l > 1$. Using this assumption, from (17), the order quantity generated in period $l + 1$ can be expressed as

$$\begin{aligned}
 u(l+1) &= y_{ref} - \sum_{j=0}^l \rho^{l+1-j} u(j) + \\
 &\quad + \rho^{n_p} \sum_{j=0}^l \rho^{l+1-j} h(j) \\
 &= y_{ref} - \rho \sum_{j=0}^{l-1} \rho^{l-j} u(j) - \rho u(l) + \\
 &\quad + \rho^{n_p+1} h(l) + \rho^{n_p+1} \sum_{j=0}^{l-1} \rho^{l-j} h(j) = y_{ref} - \rho y_{ref} + \\
 &\quad + \rho \left[y_{ref} - \sum_{j=0}^{l-1} \rho^{l-j} u(j) + \rho^{n_p} \sum_{j=0}^{l-1} \rho^{l-j} h(j) \right] - \\
 &\quad - \rho u(l) + \rho^{n_p+1} h(l) = (1 - \rho) y_{ref} + \rho u(l) - \\
 &\quad - \rho u(l) + \rho^{n_p+1} h(l) = (1 - \rho) y_{ref} + \rho^{n_p+1} h(l).
 \end{aligned} \tag{19}$$

Since l is an arbitrary positive integer, we conclude that (16) actually holds for any integer $k \geq 1$. This ends the proof of the lemma.

Theorem 1. The order quantities generated by policy (15) are always bounded, and for any $k \geq 0$ the ordering signal satisfies the following set of inequalities

$$\begin{aligned}
 (1 - \rho) y_{ref} &\leq u(k) \leq \\
 &\leq \max \{ y_{ref}, (1 - \rho) y_{ref} + \rho^{n_p+1} d_{max} \}.
 \end{aligned} \tag{20}$$

Proof. It follows from relation (15) and the system initial conditions that $u(0) = y_{ref}$, which means that the theorem is satisfied for $k = 0$. On the other hand, since $0 \leq h(\cdot) \leq d_{max}$, from Lemma 1 for any $k > 0$, we get

$$(1 - \rho) y_{ref} \leq u(k) \leq (1 - \rho) y_{ref} + \rho^{n_p+1} d_{max}. \tag{21}$$

This ends the proof.

The practical considerations of inventory management in real systems dictate the requirement for ensuring finite warehouse capacity that should be reserved at the distribution center to accommodate the stock. The next theorem demonstrates that the on-hand stock never exceeds y_{ref} . This means that in order to provide the storage space for the goods at the center, it suffices to assign the warehouse of capacity y_{ref} .

Theorem 2. If policy (15) is applied to control the flow of goods in system (5)–(6), then the stock level is always upper-bounded, i.e.

$$\forall_{k \geq 0} y(k) \leq y_{ref}. \tag{22}$$

Proof. The warehouse at the distribution center is empty for any $k \leq n_p = n - 1$. Hence, it suffices to show that the proposition is satisfied for any $k \geq n$. Let us assume that for some integer $l \geq n$, $y(l) \leq y_{ref}$. We will demonstrate that this assumption implies that the theorem is also true for $l + 1$.

Based on the inventory balance equation (2) the stock level in the $l + 1$ period can be expressed as

$$y(l+1) = \rho y(l) + u(l - n_p) - h(l). \tag{23}$$

Applying (4) and (17), we get

$$\begin{aligned}
 y(l+1) &= \rho y(l) + y_{ref} - \rho \sum_{j=0}^{l-n_p-1} \rho^{l-n_p-1-j} u(j) + \\
 &\quad + \rho^{n_p+1} \sum_{j=0}^{l-n_p-1} \rho^{l-n_p-1-j} h(j) - h(l) \\
 &= \rho y(l) + y_{ref} - \rho y(l) - \sum_{j=l-n_p}^{l-1} \rho^{l-j} h(j) - h(l) \\
 &= y_{ref} - \sum_{j=l-n_p}^l \rho^{l-j} h(j).
 \end{aligned} \tag{24}$$

Since $h(\cdot)$ is always nonnegative, $y(l + 1) \leq y_{ref}$. Using the principle of the mathematical induction we conclude that the proposition is valid for any review period $k \geq 0$.

It follows from Theorem 2 that if for the considered inventory system the warehouse of size y_{ref} is assigned at the distribution center, then all the incoming shipments can be stored locally, and any cost associated with emergency storage is eliminated. Apart from the efficient warehouse space management, a successful inventory control strategy in modern supply chain is expected to achieve high service level. The proposition formulated below shows how the reference stock level should be selected so that all of the demand imposed on the distribution center is satisfied from the readily available resources, and the cost of lost sales is reduced to zero.

Theorem 3. If policy (15) is applied to control the flow of goods in system (5)–(6), and the reference stock level satisfies the following inequality

$$y_{ref} > d_{max} \sum_{j=0}^{n_p} \rho^j, \tag{25}$$

then for any $k \geq n_p + 1$ the on-hand stock level is strictly positive.

Proof. It follows from (1) that the realized demand is always upper bounded, i.e. for any integer $k \geq 0$ the inequality $h(k) \leq d_{max}$ holds. Consequently, taking into account (24) and the theorem assumption (25) we have for $k \geq n_p + 1$

$$\begin{aligned}
 y(k) &= y_{ref} - \sum_{j=k-1-n_p}^{k-1} \rho^{k-1-j} h(j) \geq \\
 &= y_{ref} - d_{max} \sum_{j=k-1-n_p}^{k-1} \rho^{k-1-j} = \\
 &= y_{ref} - d_{max} \sum_{j=0}^{n_p} \rho^j > 0.
 \end{aligned} \tag{26}$$

This completes the proof of Theorem 3.

Remark 1. The required warehouse capacity stated in Theorem 3 is specified following the worst-case uncertainty analysis (for an instructive insight how this methodology relates to production-distribution systems see e.g. [3]). However, since the value given in (25) scales linearly with demand, in the situation when the mean demand differs significantly from the maximum one, it may be convenient to substitute d_{\max} with some positive $d_L < d_{\max}$. In such a case the 100% service level is no longer ensured, yet the average stock level, and as a consequence the holding costs, will be reduced.

3.3. Reaching-law-based SM controller design. A possible drawback of the linear dead-beat controller (15) is the required high initial order quantity which can be difficult to provide by suppliers with capacity limitations. Therefore, in order to maintain excellent dynamics offered by the dead-beat scheme, and at the same time conform to the supplier limitations, a different structure needs to be applied. For this purpose we propose to use the concept of reaching law in the form proposed by Golo and Milosavljević [17]. This reaching law allows us to control the way the system representative point approaches the sliding plane. As a consequence of applying the reaching law, instead of requiring the point to reach the plane in one step as it was assumed in the design of controller (15), the reaching phase is extended over several periods thus reducing the control effort necessary to cover large initial distance from the plane. We will show that a properly selected reaching law allows us to meet the input constraint

$$0 \leq u(k) \leq u_{\max}, \quad (27)$$

where $u_{\max} > (1 - \rho)y_{ref} + \rho^n d_{\max}$, and at the same time preserve good system dynamics provided by the dead-beat control.

The reaching law described in [17] can be synthesized in the following way

$$s(k+1) - s(k) = -\Phi[s(k)], \quad (28)$$

where

$$\Phi[s(k)] = \min\{|s(k)|, \delta_1 |s(k)| + \delta_2 \text{sgn}[s(k)]\}, \quad (29)$$

$0 \leq \delta_1 < 1$, and $\delta_2 > 0$. The $\text{sgn}(x)$ function in (29) equals either -1 or 1 depending on the value of argument x , i.e. $\text{sgn}(x) = -1$ if $x \leq 0$, and $\text{sgn}(x) = 1$ for $x > 0$. With this reaching law applied the system representative point is guaranteed to reach the hyperplane $s(k) = \mathbf{c}^T \mathbf{e}(k) = 0$ monotonically in a finite number of steps in a way determined by the choice of coefficients δ_1 and δ_2 . For the purpose of further analysis we can present (28)–(29) in the alternative way

$$s(k) = \mathbf{c}^T \mathbf{e}(k) + f(k) = 0, \quad (30)$$

where strictly monotonic function $f(\cdot)$ is defined as

$$\begin{cases} f(k+1) = (1 - \delta_1)f(k) - \delta_2 \text{sgn}[s(k)] \\ \quad \quad \quad \text{for } k < k_0, \quad k_0 \in C_+, \\ f(k+1) = 0 \quad \quad \text{for } k \geq k_0. \end{cases} \quad (31)$$

Function $f(\cdot)$ represents the distance which remains to be covered by the representative point before it reaches the sliding plane $\mathbf{c}^T \mathbf{e}(k) = 0$.

We need to select parameters δ_1 and δ_2 such that input constraint (27) is satisfied. Substituting (5) into $\mathbf{c}^T \mathbf{e}(k+1) + f(k+1) = 0$, we arrive at

$$u(k) = (\mathbf{c}^T \mathbf{b})^{-1} \{ \mathbf{c}^T [\mathbf{x}_d - \mathbf{A}\mathbf{x}(k)] + f(k+1) \}. \quad (32)$$

Applying (13) we get

$$\begin{aligned} u(k) &= y_{ref} - \rho^{n_p+1} y(k) - \\ &- \sum_{j=k-n_p}^{k-1} \rho^{k-j} u(j) + f(k+1)/c_n. \end{aligned} \quad (33)$$

We assume that $f(0) = -\mathbf{c}^T \mathbf{e}(0) = -c_n y_{ref}$. Since $f(\cdot)$ is strictly monotonic this assumption also implies that for any $k \in [0; k_0)$ function $f(\cdot)$ and coefficient c_n have opposite signs. Before we decide on the choice of the reaching law parameters, we state the relation between the control signal established according to (33) and the realized demand $h(\cdot)$.

At the initial time we have

$$u(0) = y_{ref} + f(1)/c_n. \quad (34)$$

Afterwards, for $k \geq 1$, the control signal satisfies the relation defined in Lemma 2.

Lemma 2. If policy (33) is applied to system (5)–(6), then for any $k \geq 1$

$$\begin{aligned} u(k) &= (1 - \rho)y_{ref} + \rho^{n_p+1} h(k-1) + \\ &+ [f(k+1) - \rho f(k)]/c_n. \end{aligned} \quad (35)$$

Proof. Similarly as in (17), substituting (4) into (33) yields

$$\begin{aligned} u(k) &= y_{ref} - \sum_{j=0}^{k-1} \rho^{k-j} u(j) + \\ &+ \rho^{n_p} \sum_{j=0}^{k-1} \rho^{k-j} h(j) + f(k+1)/c_n. \end{aligned} \quad (36)$$

For $k = 1$, from (36) we get

$$\begin{aligned} u(1) &= y_{ref} - \rho u(0) + \rho \rho^{n_p} h(0) + f(2)/c_n = \\ &= (1 - \rho)y_{ref} + \rho^{n_p+1} h(0) + [f(2) - \rho f(1)]/c_n, \end{aligned} \quad (37)$$

which shows that the lemma is indeed satisfied for $k = 1$. Let us assume that (35) is true for all integers up to some $l > 1$. Taking similar steps as presented in (19), the order quantity generated in period $l + 1$ can be expressed as

$$\begin{aligned}
 u(l+1) &= y_{ref} - \sum_{j=0}^l \rho^{l+1-j} u(j) + \\
 &+ \rho^{n_p} \sum_{j=0}^l \rho^{l+1-j} h(j) + f(l+2)/c_n = \\
 &= y_{ref} - \rho \sum_{j=0}^{l-1} \rho^{l-j} u(j) + \rho \rho^{n_p} \sum_{j=0}^{l-1} \rho^{l-j} h(j) - \\
 &- \rho u(l) + \rho \rho^{n_p} h(l) + f(l+2)/c_n = \\
 &= y_{ref} - \rho y_{ref} + \rho u(l) - \rho u(l) + \rho \rho^{n_p} h(l) - \\
 &- \rho f(l+1)/c_n + f(l+2)/c_n = \\
 &= (1-\rho)y_{ref} + \rho^{n_p+1} h(l) + \\
 &+ [f(l+2) - \rho f(l+1)]/c_n.
 \end{aligned} \tag{38}$$

Since l is an arbitrary positive integer, we conclude that (35) actually holds for any integer $k \geq 1$. This ends the proof of the lemma.

The comparison of (31) and (35) indicates that a suitable choice for δ_1 is the decay factor $\sigma = 1 - \rho$. Consequently, in order to complete the design of the reaching law, we need to select δ_2 such that $u(k)$ never exceeds u_{\max} . Substituting (31) into (35) with $\delta_1 = 1 - \rho$ results in

$$u(k) = \begin{cases} (1-\rho)y_{ref} + \rho^{n_p+1}h(k-1) - \delta_2 \text{sgn}[s(k)]/c_n & \text{for } k < k_0, \\ (1-\rho)y_{ref} + \rho^{n_p+1}h(k-1) & \text{for } k \geq k_0. \end{cases} \tag{39}$$

It follows from (1) that $0 \leq h(\cdot) \leq d_{\max}$. Therefore, since $n = n_p + 1$, the control signal is nonnegative and bounded by $(1-\rho)y_{ref} + \rho^n d_{\max} < u_{\max}$ for any $k \geq k_0$. Obviously, no request placed at the distribution center can be realized until the first items arrive in period n_p , and $h(k < n_p) = 0$. As a consequence, in order to ensure that condition (27) is satisfied for all $k < k_0$, taking into account (35) and (39), we conclude that parameter δ_2 should obey the following constraint

$$\begin{aligned}
 \delta_2 &\leq |c_n| [u_{\max} - (1-\rho)y_{ref}] \\
 &\text{for } 0 \leq k \leq n_p,
 \end{aligned} \tag{40}$$

$$\begin{aligned}
 \delta_2 &\leq |c_n| \{u_{\max} - [(1-\rho)y_{ref} + \rho^{n_p+1}d_{\max}]\} \\
 &\text{for } k > n_p.
 \end{aligned}$$

This ends the design of the reaching law. The obtained controller calculates the order quantities to be placed at the supplier from equation (33) with function $f(\cdot)$ defined by (35). Parameters of function $f(\cdot)$ are selected as $\delta_1 = 1 - \rho$ and δ_2 as the largest value satisfying inequalities (40). The properties of the proposed nonlinear controller will now be formulated as two theorems.

Theorem 4. If policy (33) is applied to system (5)–(6), then the on-hand stock is always upper-bounded by y_{ref} .

Proof. The warehouse at the distribution center is empty for any $k \leq n_p$. Hence, it suffices to show that the proposition is satisfied for all $k > n_p$. Using Lemma 2, the stock level (4) can be presented as

$$\begin{aligned}
 y(k) &= \rho^{k-n_p-1} u(0) + \sum_{j=1}^{k-n_p-1} \rho^{k-n_p-1-j} u(j) - \\
 &- \sum_{j=0}^{k-1} \rho^{k-1-j} h(j) = \rho^{k-n_p-1} y_{ref} + \rho^{k-n_p-1} f(1)/c_n + \\
 &+ \sum_{j=1}^{k-n_p-1} \rho^{k-n_p-1-j} [(1-\rho)y_{ref} + \rho^{n_p+1}h(j-1)] + \\
 &+ \sum_{j=1}^{k-n_p-1} \rho^{k-n_p-1-j} [f(j+1) - \rho f(j)]/c_n - \\
 &- \sum_{j=0}^{k-1} \rho^{k-1-j} h(j).
 \end{aligned} \tag{41}$$

By manipulating the sums in (41), we obtain

$$\begin{aligned}
 y(k) &= \rho^{k-n_p-1} y_{ref} + (1-\rho)y_{ref} \sum_{j=1}^{k-n_p-1} \rho^{k-n_p-1-j} + \\
 &+ \sum_{j=1}^{k-n_p-1} \rho^{k-j} h(j-1) - \sum_{j=0}^{k-1} \rho^{k-1-j} h(j) + f(k-n_p)/c_n = \\
 &= \rho^{k-n_p-1} y_{ref} + (1-\rho^{k-n_p-1}) y_{ref} - \\
 &- \sum_{j=k-n_p-1}^{k-1} \rho^{k-1-j} h(j) + f(k-n_p)/c_n = \\
 &= y_{ref} - \sum_{j=k-n_p-1}^{k-1} \rho^{k-1-j} h(j) + f(k-n_p)/c_n.
 \end{aligned} \tag{42}$$

Since the realized demand $h(\cdot)$ is always nonnegative, and $\forall k f(k)$ and c_n have opposite signs, $y(k)$ given by (41) never exceeds its demand value. This ends the proof.

Theorem 5. If policy (33) is applied to system (5)–(6), and the reference stock level satisfies inequality (25), then for any $k \geq n + k_0$ the stock level is strictly positive and demand is entirely satisfied from the readily available resources.

Proof. It follows from (31) that for $k > k_0$ function $f(k) = 0$. Consequently, for $k \geq k_0$, the nonlinear controller (33) becomes equivalent to the linear control law (15), whose action influences the stock level for $k \geq n + k_0$. Since both controllers incorporate the order history in exactly the same way, then taking into account relation (25), the proposition is valid as a direct consequence of Theorem 3. This completes the proof.

Remark 2. By comparing Theorems 4 and 5 with Theorems 2 and 3, one can notice that nonlinear policy (33) imposes the same storage space requirements for obtaining the maximum service level as the linear dead-beat scheme (15). It follows from Theorem 5 that the additional benefit of conforming to the input constraint (27) demonstrated by the nonlinear controller is obtained at the price of a possibly increased initial period before the system reaches the state of all the sales realized from the on-hand stock.

4. Relation to order-up-to policy

In the case when demand forecasting is not used, the classical OUT policy can be synthesized in the following way (see e.g. [29] for a concise, comprehensive explanation of the role of various components of typical inventory management policies)

$$u(k) = y_{OUT} - y(k) - \Omega(k), \quad (43)$$

where y_{OUT} is the order-up-to level, $y(k)$ is the current stock value, and $\Omega(k)$ denotes the pending order (order placed but not yet realized due to lead-time). Notice that in the considered system with fixed delay the pending order can be calculated by summing orders $u(\cdot)$ generated in the last n_p periods.

Therefore, $\Omega(k) = \sum_{j=k-n_p}^{k-1} u(j)$, and the OUT policy can be rewritten as

$$u(k) = y_{OUT} - y(k) - \sum_{j=k-n_p}^{k-1} u(j). \quad (44)$$

Comparing strategy (15) with OUT policy (44) we can notice a similar control structure which involves the measurement of the current stock level and the calculations performed on the order history. However, our scheme explicitly accounts for the effect caused by deteriorating stock which is quantified by the powers of $\rho = 1 - \sigma$. The characteristic polynomial when strategy (15) is applied equals z^n , which guarantees stable, oscillation-free closed-loop system performance. In turn, the resultant characteristic polynomial when strategy (44) is used in system (5)–(6) has the following form

$$z^n + \sigma(z^{n-1} + z^{n-2} + \dots + z). \quad (45)$$

Jury test [30] applied to (45) indicates that OUT policy (44) maintains asymptotic stability for all $\sigma \in [0, 1)$. However, oscillations cannot be avoided unless the decay factor $\sigma = 0$. In order to notice this property, suppose that there exists at least one stabilizing real root $z_0 \in (0, 1)$. Substituting z_0 into (45) we get the sum of all positive terms $z_0^n + \sigma \sum_{j=1}^{n-1} z_0^j > 0$. Hence, all the nonzero roots of (45) are negative real or complex which implies oscillatory response. In consequence, the classical OUT policy is expected not only to provide slower convergence to steady-state than our strategy when used in the system with perishable inventory, but additionally it may lead to oscillations which degrade the system performance and increase economical costs. Notice also

that our strategy becomes equivalent to the classical OUT policy when applied to the system without perishables ($\rho = 1$). As a result, when applied to the standard inventory system with nondeteriorating stock, all the properties stated in the theorems will be valid for the OUT policy with ρ set as one.

5. Numerical example

We verify the properties of the proposed SM policies (15) and (33) in a series of simulation tests. The system parameters are chosen in the following way: review period $T = 1$ day, lead-time $L_p = n_p T = 4$ days, inventory decay factor $\sigma = 0.1$, which implies $\rho = 1 - \sigma = 0.9$, and the maximum daily demand at the distribution center $d_{max} = 60$ items. The actual demand evolves according to the pattern illustrated in Fig. 3, which reflects abrupt changes in a seasonal trend.

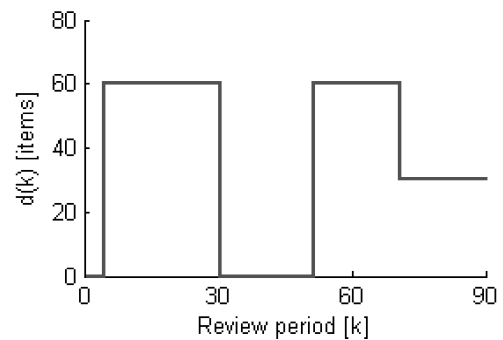

Fig. 3. Demand at the distribution center

We run two series of simulations. In the first series, it is assumed that arbitrarily high order can be placed at the supplier, whereas in the second one, we consider the case of the supplier subject to capacity limitations of 70 items. Thus, in the second series of simulations it is assumed that the order may not exceed $u_{max} = 70$ items. For the purpose of comparison we repeat the tests for the classical OUT policy. Two different settings of the order-up-to level y_{OUT} are considered: in one simulation (curve (b) in the graphs) it is adjusted to achieve the same service level as the SM policies, whereas in the second test in each series of simulations y_{OUT} is set such that the policies result in the identical storage space assignment (curve (c) in the graphs).

Test 1. In the first scenario we test the controller performance in the situation of an unconstrained supply source ($u_{max} = \infty$). In order to ensure full demand satisfaction, according to Theorem 3, the reference stock level for policy (15) should be bigger than 246 items. We select $y_{ref} = 250$ items. For the OUT policy we set two different order-up-to levels: in the first simulation it is set as 380 items, whereas in the second one it is adjusted to 290 items. The orders generated by our controller (a) and the classical inventory policy (b) and (c) are shown in Fig. 4, and the on-hand stock in Fig. 5. It is clear from the graphs that the SM controller quickly responds to the sudden changes in the demand trend without oscillations or overshoots. Moreover, the on-hand stock level resulting from the application of policy (15) does not increase beyond the

warehouse capacity, and it never drops to zero after the initial phase which implies full demand satisfaction. The OUT policy exhibits oscillations and requires bigger storage space to accommodate the stock to achieve the same service level (curve (b) in Fig. 5), which implies an increased holding cost. On the other hand, if the safety stock level is reduced for the OUT policy to maintain the same storage space requirements as the ones imposed by our controller, the OUT service level drops to 95%. In that case, curve (c) in the graphs, large oscillations appear in the ordering signal generated by the OUT policy leading to the bullwhip effect, which is avoided by our scheme. This clearly shows the benefits of application of a formal methodology to the design of control schemes for perishable inventory systems.

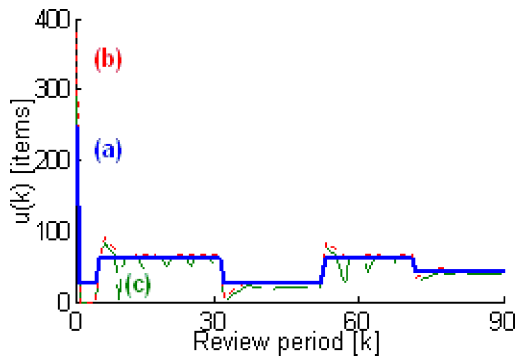

Fig. 4. Order quantities: a) policy (15), b) OUT policy ($y_{OUT} = 380$ items), c) OUT policy ($y_{OUT} = 290$ items)

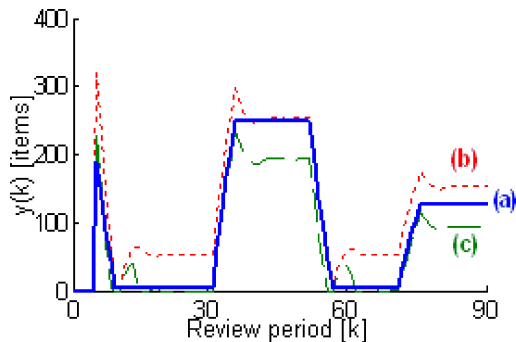

Fig. 5. On-hand stock level: a) policy (15), b) OUT policy ($y_{OUT} = 380$ items), c) OUT policy ($y_{OUT} = 290$ items)

Test 2. In the second scenario, we assume that the supplier cannot provide more goods in a single review period than $u_{max} = 70$ items. Since we deal with a saturating supply source we apply controller (33) with the parameters of the reaching law set as: $\delta_1 = 1 - \rho = 0.1$, $\delta_2 = 45$ for $0 \leq k \leq 4$, and $\delta_2 = 9.57$ for $k > 4$ (calculated according to (40)). For fair comparison we introduce a saturation element for the OUT policy which does not permit the order quantity to exceed 70 items. The orders generated by both policies are shown in Fig. 6, and the on-hand stock in Fig. 7. It is evident from the plots that controller (33) conforms to the input constraint and ensures full demand satisfaction with smaller stock than the OUT policy (curve (b)). If the storage space

requirements of the OUT policy are reduced to a similar level as controller (33), the service level achieved by the OUT policy decreases to 96%.

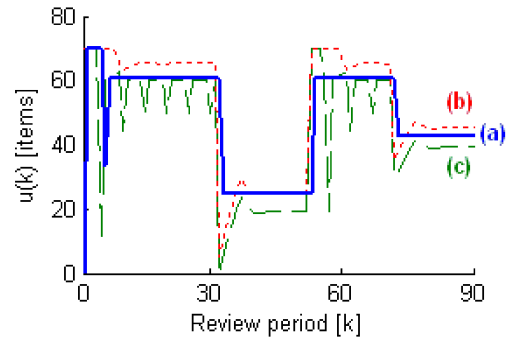

Fig. 6. Order quantities: a) policy (33), b) OUT policy ($y_{OUT} = 380$ items), c) OUT policy ($y_{OUT} = 290$ items)

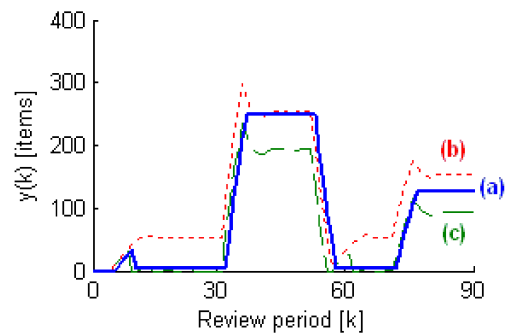

Fig. 7. On-hand stock level: a) policy (33), b) OUT policy ($y_{OUT} = 380$ items), c) OUT policy ($y_{OUT} = 290$ items)

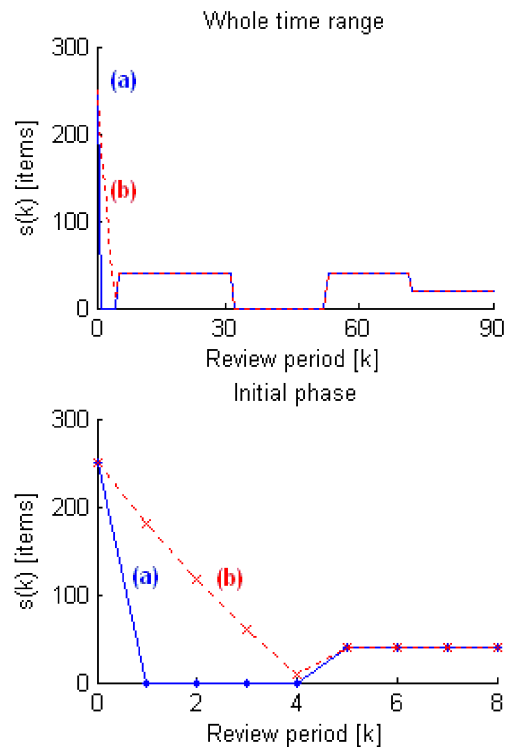

Fig. 8. Sliding variable: a) policy (15), b) policy (33)

In Fig. 8 we show the evolution of the sliding variable obtained in Test 1 (curve (a)) and 2 (curve (b)). We can see that the system representative point reaches the sliding plane $\mathbf{c}^T \mathbf{e}(k) = 0$ in finite time, and never leaves a small band around the plane afterwards. This means that the reaching conditions are met, and, despite the presence of the external mismatched disturbance, the stability of the quasi-sliding motion is ensured. In the case of controller (15) the sliding plane is reached in one step, precisely as assumed in the design procedure, whereas in the case of controller (33) the reaching phase is extended over several periods ($k_0 = 4$).

6. Conclusions

In this paper, a new supply policy for periodic-review inventory systems with deteriorating stock was designed using strict control-theoretic methodology. The proposed policy based on sliding-mode dead-beat control provides fast reaction to the changes in market conditions and stable system operation for arbitrary positive lead-time. It also guarantees that the entire demand is satisfied from the on-hand stock, thus eliminating the risk of missed service opportunities and necessity of backorders. Since the dead-beat scheme requires large order quantities to be delivered in the initial phase of the control process, we also propose a modified controller which ensures that the ordering signal never exceeds the supplier capabilities. The enhanced nonlinear control law, based on the reaching law approach, preserves the desirable properties of the original strategy and guarantees that input constraint is satisfied. The proposed controllers obtained from a systematic design procedure outperform the classical OUT policy in terms of smaller holding costs and higher service level.

The designed discrete SM control laws have simple and intuitive form. From the managerial perspective they can be interpreted as generating orders proportional to the difference between the current on-hand stock and its reference value decreased by the amount of open orders quantified by the rate of deterioration within the last lead-time. By expressing the control laws in a closed-form we obtain ordering rules which are straightforward in software implementation, and easy to deploy in real inventory management systems.

Acknowledgments. This work was financed by the Polish State budget in the years 2010–2012 as a research project N N514 108638 “Application of regulation theory methods to the control of logistic processes”. P. Ignaciuk gratefully acknowledges financial support provided by the Foundation for Polish Science (FNP). He is also a scholarship holder of the project entitled “Innovative Education without Limits – Integrated Progress of the Technical University of Łódź” supported by the European Social Fund.

REFERENCES

- [1] P.H. Zipkin, *Foundations of Inventory Management*. McGraw-Hill, New York, 2000.
- [2] M. Ortega and L. Lin, “Control theory applications to the production-inventory problem: a review”, *Int. J. Production Research* 42 (11), 2303–2322 (2004).
- [3] H. Sarimveis, P. Patrinos, C.D. Tarantilis, and C.T. Kiranoudis, “Dynamic modeling and control of supply chain systems: a review”, *Computers & Operations Research* 35 (11), 3530–3561 (2008).
- [4] S. Nahmias, “Perishable inventory theory: a review”, *Operations Research* 30 (4), 680–708 (1982).
- [5] F. Rifaat, “Survey of literature on continuously deteriorating inventory models”, *J. Operational Research Society* 42 (1), 27–37 (1991).
- [6] S.K. Goyal and B.C. Giri, “Recent trends in modeling of deteriorating inventory”, *Eur. J. Operational Research* 134 (1), 1–16 (2001).
- [7] I. Karaesmen, A. Scheller-Wolf, and B. Deniz, “Managing perishable and aging inventories: review and future research directions”, in: *Handbook of Production Planning*, eds. K. Kempf, P. Keskinocak, and R. Uzsoy, Kluwer, Dordrecht, 2008.
- [8] A. Bensoussan, G. Nissen, and Ch.S. Tapiero, “Optimum inventory and product quality control with deterministic and stochastic deterioration – an application of distributed parameters control systems”, *IEEE Trans. on Automatic Control* 20 (3), 407–412 (1975).
- [9] A. Andijani and M. Al-Dajani, “Analysis of deteriorating inventory/production systems using a linear quadratic regulator”, *Eur. J. Operational Research* 106 (1), 82–89 (1998).
- [10] M.D.S. Aliyu, and E.K. Boukas, “Discrete-time inventory models with deteriorating items”, *Int. J. Systems Science* 29 (9), 1007–1014 (1998).
- [11] L. Rodrigues and E.-K. Boukas, “Piecewise-linear H_∞ controller synthesis with applications to inventory control of switched production systems”, *Automatica* 42 (8), 1245–1254 (2006).
- [12] E.-K. Boukas, P. Shi, and R.K. Agarwal, “An application of robust control technique to manufacturing systems with uncertain processing time”, *Optimal Control Applications and Methods* 21 (6), 257–268 (2000).
- [13] Č. Milosavljević, “General conditions for the existence of a quasisliding mode on the switching hyperplane in discrete variable structure systems”, *Automation and Remote Control* 46 (3), 307–314 (1985).
- [14] W. Gao, Y. Wang, and A. Homaifa, “Discrete-time variable structure control systems”, *IEEE Trans. on Industrial Electronics* 42 (2), 117–122 (1995).
- [15] A. Bartoszewicz, “Remarks on ‘Discrete-time variable structure control systems’”, *IEEE Transactions on Industrial Electronics* 43 (1), 235–238 (1996).
- [16] A. Bartoszewicz, “Discrete time quasi-sliding mode control strategies”, *IEEE Trans. on Industrial Electronics* 45 (4), 633–637 (1998).
- [17] G. Golo and Č. Milosavljević, “Robust discrete-time chattering free sliding mode control”, *Systems & Control Letters* 41 (1), 19–28 (2000).
- [18] B. Bandyopadhyay and S. Janardhanan, *Discrete-Time Sliding Mode Control. A Multirate Output Feedback Approach*, Springer-Verlag, Berlin, 2006.
- [19] M. Yan and Y. Shi, “Robust discrete-time sliding mode control for uncertain systems with time-varying state delay”, *IET Control Theory & Applications* 2 (8), 662–674 (2008).
- [20] Č. Milosavljević, B. Peruničić-Dražević, B. Veselić, and D. Mitić, “Sampled data quasi-sliding mode control strategies”, *IEEE Int. Conf. on Industrial Technologies* 1, 2640–2645 (2006).

- [21] P. Ignaciuk and A. Bartoszewicz, "Linear quadratic optimal discrete time sliding mode controller for connection oriented communication networks", *IEEE Trans. on Industrial Electronics* 55 (11), 4013–4021 (2008).
- [22] B. Bandyopadhyay, F. Deepak, and K.-S. Kim, *Sliding Mode Control Using Novel Sliding Surfaces in Lecture Notes in Control and Information Sciences*, vol. 392, Springer-Verlag, Berlin, 2009.
- [23] A. Bartoszewicz and A. Nowacka-Leverton, *Time-Varying Sliding Modes for Second and Third Order Systems*, Springer-Verlag, Berlin, 2009.
- [24] A. Bartoszewicz and A. Nowacka-Leverton, "ITAE optimal sliding modes for third order systems with input signal and state constraints", *IEEE Trans. on Automatic Control* 55 (8), 1928–1932 (2010).
- [25] P. Ignaciuk and A. Bartoszewicz, "Discrete-time sliding-mode congestion control in multisource communication networks with time-varying delay", *IEEE Trans. on Control Systems Technology* 19, (2010) (to be published).
- [26] P. Ignaciuk and A. Bartoszewicz, "LQ optimal sliding mode supply policy for periodic review inventory systems", *IEEE Trans. on Automatic Control* 55 (1), 269–274 (2010).
- [27] P. Ignaciuk and A. Bartoszewicz, "LQ optimal and reaching law based sliding modes for inventory management systems", *Int. J. Systems Science* 42, (2010) (to be published).
- [28] W. Gao and J. C. Hung, "Variable structure control of nonlinear systems: a new approach", *IEEE Trans. on Industrial Electronics* 40 (1), 45–55 (1993).
- [29] R.D.H. Warburton, "An optimal, potentially automatable ordering policy", *Int.J. Production Economics* 107 (2), 483–495 (2007).
- [30] E.I. Jury, *Theory and Application of the Z-Transform Method*, Wiley, New York, 1964.